

EIA PUBLICATION

Style Manual for Standards and Other Publications of EIA

EP-7-C
(Revision of EP-7-B)

NOVEMBER 2000

ELECTRONIC INDUSTRIES ALLIANCE



NOTICE

EIA Engineering Standards and Publications are designed to serve the public interest through eliminating misunderstandings between manufacturers and purchasers, facilitating interchangeability and improvement of products, and assisting the purchasers in selecting and obtaining with minimum delay the proper product for their particular needs. Existence of such Standards and Publications shall not in any respect preclude any member or nonmember of EIA from manufacturing or selling products not conforming to such Standards and Publications, nor shall the existence of such Standards and Publications preclude their voluntary use by those other than EIA members, whether the standard is to be used either domestically or internationally.

Standards and Publications are adopted by EIA in accordance with the American National Standards Institute (ANSI) patent policy. By such action, EIA does not assume any liability to any patent owner, nor does it assume any obligation whatever to parties adopting the Standard or Publication.

Technical Publications are distinguished from EIA Standards or Interim Standards, in that they contain a compilation of engineering data or information useful to the technical community and represent approaches to good engineering practices that are suggested by the formulating committee.

This publication is not intended to preclude or discourage other approaches that similarly represent good engineering practice, or that may be acceptable to, or have been accepted by, appropriate bodies. Parties who wish to bring other approaches to the attention of the formulating committee to be considered for inclusion in future revisions of this publication are encouraged to do so. It is the intention of the formulating committee to revise and update this publication from time to time as may be occasioned by changes in technology, industry practice, or government regulations, or for other appropriate reasons.

(Developed by the JEDEC JC-10 Committee on Terms and Definitions.)

Published by

©ELECTRONIC INDUSTRIES ALLIANCE 2000
Technology Strategy & Standards Department
2500 Wilson Boulevard
Arlington, VA 22201

All Rights Reserved
Printed in U.S.A.

PLEASE!

DON'T VIOLATE
THE
LAW!

This document is copyrighted by the Electronic Industries Alliance and may not be reproduced without permission.

Organizations may obtain permission to reproduce a limited number of copies through entering into a license agreement. For information, contact:

Global Engineering Document
1500 Inverness Way East
Englewood, CO 80112-5776
or call (703) 907-7559

STYLE MANUAL FOR STANDARDS AND OTHER PUBLICATIONS OF EIA

CONTENTS

	Page
Foreword	iv
Introduction	iv
1 Scope	1
2 Normative references	1
3 Terms and definitions	2
4 General principles	4
4.1 Objectives	4
4.2 Homogeneity	4
4.3 Consistency of standards	5
4.4 Implementation	5
4.5 Planning	5
4.6 Procedural policies	5
4.7 Legal policies	5
5 Structure	6
5.1 Subdivision of the subject matter	6
5.1.1 General	6
5.1.2 Subdivision of the subject matter within a series of parts	7
5.1.3 Subdivision of the subject matter within an individual standard	8
5.2 Descriptions and numbering of divisions and subdivisions	10
5.2.1 Parts	10
5.2.2 Sections	10
5.2.3 Clauses	10
5.2.4 Subclauses	11
5.2.5 Paragraphs	11
5.2.6 Lists	12
5.2.7 Annexes	13
5.2.8 Bibliography	13
5.2.9 Index	13

STYLE MANUAL FOR STANDARDS AND OTHER PUBLICATIONS OF EIA

CONTENTS *(continued)*

	Page
6 Drafting	14
6.1 Preliminary informative elements	14
6.1.1 Cover	14
6.1.2 Notice and statement outlining similarities with non-EIA standards	14
6.1.3 Table of contents	15
6.1.4 Foreword	16
6.1.5 Introduction	16
6.2 General normative elements	17
6.2.1 Scope	17
6.2.2 Normative references	18
6.3 Technical normative elements	19
6.3.1 Terms and definitions	19
6.3.2 Symbols and abbreviated terms	20
6.3.3 Requirements	20
6.3.4 Sampling	21
6.3.5 Test methods	21
6.3.6 Classification and designation	22
6.3.7 Marketing, labeling, and packaging	22
6.3.8 Application notes	22
6.3.9 Normative annexes	22
6.4 Supplementary informative elements	22
6.4.1 Informative annexes	22
6.4.2 Bibliographic references	23
6.4.3 Index	25
6.4.4 Related EIA documents	25
6.5 Other informative elements	26
6.5.1 Notes and examples integrated into the text	26
6.5.2 Footnotes to the text	26
6.6 Common rules and elements	27
6.6.1 Verbal forms for the expression of provisions	27
6.6.2 Spelling, abbreviations, style, and grammar	27
6.6.3 Tradenames, patents, and copyrights	30
6.6.4 Figures	32
6.6.5 Tables	35
6.6.6 References	40
6.6.7 Representation of numbers and numerical values	42
6.6.8 Quantities, units, symbols, and signs	43
6.6.9 Mathematical formulas	44
6.6.10 Dimensions and tolerances	47
6.6.11 Page numbers	47
6.6.12 Page headings	47
6.6.13 Special needs	48

STYLE MANUAL FOR STANDARDS AND OTHER PUBLICATIONS OF EIA

CONTENTS *(continued)*

	Page
7 Presentation of manuscripts	48
7.1 Page dimensions	48
7.2 Layout	49
7.2.1 Text	49
7.2.2 Tables and figures	49
7.3 Typography	50
 Annexes	
A (informative) Differences between EP-7-C and ISO/IEC Directives, Part 3, 1997	52
B (informative) Differences between EP-7-C and EP-7-B	53
C (informative) Basic standards of EIA, ANSI, and IEEE	54
C.1 Introduction	54
C.2 Reference work for language	54
C.3 Standardized terminology	54
C.4 Mathematical signs and symbols	54
C.5 Quantities, units, and their symbols	54
C.6 Abbreviated terms	55
C.7 Technical drawings	55
C.8 Graphical symbols and diagrams	55
D (normative) Preparation of the final manuscript by the formulating committee	56
D.1 Responsibility of formulating committees and working groups	56
D.2 Document submission for publication	56
D.2.1 Choice of formats	56
D.2.2 Electronic format	56
D.2.3 Hard-copy format	57
D.3 Artwork	57
D.4 Mathematical expressions	57
E (normative) Functions of the EIA Technology Strategy and Standards Department Publications Office	58
E.1 General	58
E.2 Editing	58
E.3 Final Approval	58
F (informative) Example of numbering of divisions and subdivisions	59
G (normative) Drafting and presentation of terms and definitions	60
G.1 General principles	60
G.1.1 Types of standards	60
G.1.2 Choice of concepts to be defined	60
G.1.3 Avoidance of duplications and contradictions	60
G.1.4 Drafting of definitions	61
G.2 Arrangement of terms	62
G.3 Presentation	62
G.3.1 Rules	62
G.3.2 Layout	62
G.3.3 Synonyms	62
G.3.4 Multiple meanings	63
G.3.5 Parentheses and brackets	63

STYLE MANUAL FOR STANDARDS AND OTHER PUBLICATIONS OF EIA

CONTENTS (*continued*)

H (normative) Drafting of the title of a document	64
H.1 Elements of the title	64
H.1.1 The introductory element	64
H.1.2 The main element	64
H.1.3 The complementary element	64
H.2 Presentation of the elements	65
H.3 Avoidance of unintentional limitation of the scope	65
H.4 Wording	65
J (normative) Verbal forms	67
K (informative) Spelling and proper wording	69
K.1 Spelling	69
K.2 Proper wording	70
L (informative) Symbols and abbreviations	71
M (informative) Illustration of a manuscript layout	73
 Tables	
1 Naming and numbering divisions and subdivisions	6
2 Example of a typical arrangement of elements in a standard	9
3 Nomenclature for the parts of a table	38
J.1 Requirement	67
J.2 Recommendations	67
J.3 Permission	68
J.4 Possibility and capability	68
J.5 Expectation	68
 Figures	
1 Page Dimensions	48
2 Two-page spread in landscape format	49
3 Two-page spread in portrait format	50
 Index	 75

Foreword

This style manual establishes requirements for the preparation of standards and certain other publications of the Electronic Industries Alliance (EIA). These requirements are intended to ensure that such documents are presented in as uniform a manner as practicable, irrespective of the technical content.

Included are requirements for content; general style; and style for special elements such as equations, tables, and figures. They will help ensure that a standard is well organized and that it is consistent in style and presentation within itself and with other standards published by EIA. Formulating committees and working groups should comply with the requirements set forth in this manual to make the product of the committee's work available for application in as short a time as possible.

The EIA Technology Strategy and Standards Department Publications Office will use this manual to resolve nontechnical comments received as a result of public review of proposed standards.

This manual is based on widely accepted usage. Its sources include the IEC/ISO Directives, Part 3 *Drafting and Presentation of International Standards, 1997* (see annex A for differences); American National Standards Institute (ANSI)-approved consensus standards on unit and letter symbols, abbreviations, drafting, and publishing practices; *Webster's Third New International Dictionary, Unabridged*; and *Merriam-Webster's Collegiate Dictionary, Tenth Edition*.

Annexes A, B, C, F, and K through N are informative; annexes D, E, G, H, and J are normative.

This revision of the style manual incorporates many changes and a complete reorganization of EP-7-B. The major part of the text remains unchanged, although the restructuring tends to suggest otherwise. Substantive differences are described in annex B. The material contained in this publication was formulated under the cognizance of the JEDEC JC-10 Committee on Terms, Definitions, and Symbols and approved by the Engineering Department Executive Committee (EDEC).

Introduction

It is recognized that amongst standards writers many different tools are used for the drafting of standards, and that these tools will not necessarily permit the same options for the presentation of text elements. Therefore, wherever possible, optional presentations have been allowed for in these rules [e.g., it is permitted to precede the items in an unordered list by dashes or bullets (see 5.2.6)]. However, for such cases it should be noted that the Electronic Industries Alliance Technology Strategy and Standards Department reserves the right to apply only one presentation in published standards.

STYLE MANUAL FOR STANDARDS AND OTHER PUBLICATIONS OF EIA

1 Scope

This style manual establishes requirements for the preparation of standards¹⁾ and certain other publications of EIA. It also gives some indication with regard to presentation.

2 Normative references

The following normative documents contain provisions that, through reference in this text, constitute provisions of this style manual. For dated references, subsequent amendments to, or revisions of, any of these publications do not apply. However, parties to agreements based in this manual are encouraged to investigate the possibility of applying the most recent editions of the normative documents indicated below. For undated references, the latest editions of the normative document referred to applies.

ANSI X3.50, *Representation for U.S. Customary, SI, and Other Units to be Used in Systems with Limited Character Sets.*

ANSI Y14.5M, *Dimensioning and Tolerancing.*

ANSI Y14.15, *Electrical and Electronics Diagrams.*

ANSI Z39.4, *Basic Criteria for Indexes.*

ANSI/ASME Y1.1, *Abbreviations for Use on Drawings and in Text.*

ANSI/ASME Y14.1M, *Metric Drawing Sheet Size and Format.*

ANSI/ASME Y14.2M, *Line Conventions and Lettering.*

ANSI/ASME Y14.3M, *Multiview and Sectional View Drawings.*

ANSI/ASME Y14.4M, *Pictorial Drawing.*

ANSI/ASME Y14.24M, *Types and Applications of Engineering Drawings.*

ANSI/IEEE Std 91, *Graphic Symbols for Logic Functions.*

ANSI/IEEE Std 100, *IEEE Standard Dictionary of Electrical and Electronic Terms.*

ANSI/IEEE Std 200, *Reference Designations for Electrical and Electronics Parts and Equipment.*

1) As used in this style manual, the word “publication” is a generic term that includes standards. Requirements that apply only to standards shall be so designated.

2 Normative references (cont'd)

ANSI/IEEE Std 260.1, *Letter Symbols for Units of Measurement (SI Units, Customary Inch-Pound Units, and Certain Other Units)*.

ANSI/IEEE Std 260.3, *Mathematical Signs and Symbols for Use in Physical Science and Technology*.

ANSI/IEEE Std 280, *Letter Symbols for Quantities Used in Electrical Science and Electrical Engineering*.

ANSI/IEEE Std 315, *Graphic Symbols for Electrical and Electronics Diagrams*.

ANSI/IEEE Std 991, *Logic Circuit Diagrams*.

ANSI/IEEE/ASTM SI 10, *Standard for Use of the International System of Units (SI): The Modern Metric System*.

EIA EP-20, *Manual of Organization and Procedure*.

JEDEC JEP104, *Reference Guide to Letter Symbols for Semiconductor Devices*.

JEDEC JEP120, *Index of Terms Defined in JEDEC Publications*.

JEDEC JESD77, *Terms, Definitions, and Letter Symbols for Discrete Semiconductor and Optoelectronic Devices*.

JEDEC JESD99, *Terms, Definitions, and Letter Symbols for Microelectronic Devices*.

JEDEC JESD100, *Terms, Definitions, and Letter Symbols for Microcomputers and Memory Integrated Circuits*.

3 Terms and definitions

For the purpose of this publication, the following terms and definitions apply.

3.1 standard: A document, established by consensus and approved by a recognized body, that provides, for common and repeated use, rules, guidelines, or characteristics for activities or their results, aimed at the achievement of the optimum degree of order in a given context.

NOTE Standards should be based on the consolidated results of science, technology, and experience, and aimed at the promotion of optimum community benefits.

[ISO/IEC Guide 2: 1996, definition 3.2]

3 Terms and definitions (cont'd)

3.1.1 international standard: A standard that is adopted by an international standardizing/standards organization and made available to the public.

[ISO/IEC Guide 2: 1996, definition 3.2.1.1]

NOTE International standards published by ISO and IEC are written with a capital “I” and “S”, i.e., “International Standard”.

3.2 normative element: An element that has provisions with which it is necessary to conform in order to be able to claim compliance with the standard.

3.3 informative element: An element that does not have any provisions with which it is necessary to conform in order to be able to claim compliance with the standard.

3.3.1 preliminary element: An informative element that identifies the standard, introduces its content, and explains its background, its development, and its relationship with other standards.

3.3.2 supplementary element: An informative element that provides additional information intended to assist in understanding or using the standard.

3.4 required element: An element whose presence in a standard is obligatory.

3.5 optional element: An element whose presence in a standard is dependent on the provisions of that standard.

3.6 provision: An expression, in the content of a normative document, that takes the form of a statement, an instruction, a recommendation, or a requirement.

NOTE These types of provisions are distinguished by the form of wording they employ; e.g., instructions are expressed in the imperative mood, recommendations by the use of the auxiliary “should”, and requirements by the use of the auxiliary “shall”.

[ISO/IEC Guide 2: 1996, definition 7.2]

3.6.1 statement: A provision that conveys information.

3.6.2 instruction: A provision that conveys an action to be performed.

[ISO/IEC Guide 2: 1996, definition 7.3]

3.6.3 recommendation: A provision that conveys advice or guidance.

[ISO/IEC Guide 2: 1996, definition 7.4]

3.6.4 requirement: A provision that conveys criteria to be fulfilled.

[ISO/IEC Guide 2: 1996, definition 7.5]

3 Terms and definitions (cont'd)

3.7 state of the art: The developed stage of technical capability at a given time as regards products, processes, and services, based on the relevant consolidated findings of science, technology, and experience.

[ISO/IEC Guide 2; 1996, definition 1.4]

4 General principles

4.1 Objectives

The objective of a standard is to define clear and unambiguous provisions in order to facilitate trade and communication. To achieve this objective, the standard shall

- be as complete as necessary within the limits specified by its scope,
- be consistent, clear, and accurate,
- take full account of the state of the art (see 3.7),
- provide a framework for future technological development, and
- be comprehensible to qualified persons who have not participated in its preparation.

4.2 Homogeneity

Uniformity of structure, of style, and of terminology shall be maintained, not only within each standard but also within a series of associated standards. The structure of associated standards and the numbering of their clauses shall, insofar as possible, be identical. Analogous wording shall be used to express analogous provisions; identical wording shall be used to express identical provisions.

The same term shall be used throughout each standard or series of standards to designate a given concept. The use of an alternative term (synonym) for a concept already defined shall be avoided. Insofar as possible (see G.1.4.8), only one meaning shall be attributed to each term chosen.

These requirements are particularly important, not only to ensure comprehension of the standard but also to derive the maximum benefit available through automated text processing techniques and computer-aided translation.

4 General principles (cont'd)

4.3 Consistency of standards

In order to achieve the aim of consistency within the complete body of standards, the text of every standard shall be in accordance with the relevant provisions of existing basic EIA, ANSI, and international standards. This requirement relates particularly to

- standardized terminology,
- principles and methods of terminology,
- quantities, units, and their symbols,
- abbreviations,
- bibliographic references,
- technical drawings, and
- graphical symbols.

In addition, the relevant technical provisions of general EIA, ANSI, and international standards shall be followed.

A list of basic standards is given in annex C.

4.4 Implementation

The content of an EIA standard shall be constructed in such a way as to permit its direct application and to facilitate its adoption with minimum change as an American national standard or international standard.

4.5 Planning

In order to ensure the timely publication of a standard, or of a series of associated standards, a list of all aspects to be covered shall be defined before detailed drafting begins so that scope(s), structure(s), and interrelationships can be established. These rules for the drafting and presentation of standards shall be applied from the very beginning of the work and through all subsequent stages to avoid delay at any stage.

4.6 Procedural policies

The instructions in this manual supplement information in EP-20, *Manual of Organization and Procedure*. Clause 5 (including its subclauses) of EP-20 outlines the administrative and procedural steps to be followed in the formulation, publication, and maintenance of EIA standards. See annex D.

4.7 Legal policies

Annex E of EP-20 is a brief summary of the EIA Legal Guides.

5 Structure

5.1 Subdivision of the subject matter

5.1.1 General

Standards are so diverse that no universally acceptable rules can be established for the subdivision of the subject matter. However, as a general rule, an individual standard shall be prepared and published as a complete entity for each subject to be standardized.

In specific cases and for practical reasons, for example, if

- the standard is likely to become too voluminous,
- subsequent portions of the content are interlinked,
- portions of the standard could be referred to in regulations, or
- portions of the standard are intended to serve for certification purposes,

the standard may be split into separate parts under the same number. The advantage is that each part can then be changed separately if the need arises.

In particular, the aspects of a product that will be of separate interest to different parties (e.g., manufacturers, certification bodies, legislative bodies) shall be clearly distinguished, preferably as parts of a standard or as separate standards. Such individual aspects include

- health and safety requirements,
- performance requirements,
- maintenance and service requirements,
- installation rules, and
- quality assessment.

The terms that shall be used to designate the divisions and subdivisions that a standard may have are shown in Table 1. For example of numbering, see annex F.

Table 1 — Naming and numbering divisions and subdivisions

Term	Example of numbering
part	9999-1
clause	1*
subclause	1.1
subclause	1.1.1
paragraph	(no number)
annex	A
* Exception: see 5.2.2	

5.1 Subdivision of the subject matter (cont'd)

5.1.2 Subdivision of the subject matter within a series of parts

There are two systems in use for subdividing into parts.

- a) Each part deals with a specific aspect of the subject and can stand alone.

EXAMPLE 1

Part 1: Definitions
Part 2: Requirements
Part 3: Test methods
Part 4: ...

EXAMPLE 2

Part 1: Definitions
Part 2: Harmonics
Part 3: Electrostatic discharge
Part 4: ...

- b) There are both common and specific aspects to the subject. The common aspects shall be given in Part 1. Specific aspects (which may modify or supplement the common aspects and therefore cannot stand alone) shall be given in individual parts.

EXAMPLE 3

Part 1: General requirements
Part 4: Particular requirements for diodes
Part 7: Particular requirements for transistors
Part 11: Particular requirements for integrated circuits

Where the system described in b) is used, care shall be taken that references in one part to another are always to the latest revision. There are two ways to achieve this.

- If the reference is made to a particular element, the reference shall be dated (see 6.6.6.5.2).
- Since the complete series of parts is normally under the control of the same technical committee, the use of undated references (see 6.6.6.5.3) is permitted, provided that corresponding changes are implemented simultaneously in all parts. The use of undated references requires a high degree of discipline by the committee responsible for the standard. Their use is not permitted between standards of different committees except where the normative reference is intentionally undated, i.e., it is accepted that it will be possible to use all future changes of the text referred to for the purposes of the referring standard.

Each part of a multipart standard shall be drafted in accordance with the rules for an individual standard as specified in this publication.

5.1 Subdivision of the subject matter (cont'd)

5.1.3 Subdivision of the subject matter within an individual standard

The elements that together form a standard may be classified in two different ways:

- a) by their normative/informative nature and their position within the structure, i.e.,
 - informative preliminary elements (see 3.5.1),
 - normative general and technical elements (see 3.4), and
 - informative supplementary elements (see 3.5.2); or
- b) by their required or optional presence (see 3.6 and 3.7).

An example of a typical arrangement is given in Table 2. Table 2 also lists the permitted content of each of the elements constituting the arrangement.

Notes integrated into the text (see 6.5.1) may be part of any element except the cover, the title, and footnotes.

A standard need not contain all the technical normative elements shown, and it may contain technical normative elements other than those shown. Both the nature of the technical normative elements and their sequence are determined by the nature of the standard in question.

Include tables and figures, as necessary, to describe the material covered by the document (see 6.6.4 and 6.6.5). When drawings or detail sheets are included in an annex to the document, they should be referenced in the text.

A standard may also contain notes and footnotes to figures and tables (see 6.6.4.8, 6.6.4.9, 6.6.5.6, and 6.6.5.7).

Terminology standards have different requirements for the subdivision of content (see annex G).

5.1 Subdivision of the subject matter (cont'd)

5.1.3 Subdivision of the subject matter within an individual standard (cont'd)

Table 2 — Example of a typical arrangement of elements in a standard

Type of element	Arrangement of elements ^a in the standard	Permitted content ^a of elements in the standard
Informative preliminary	Cover	(see 6.1.1 and 6.1.2)
	<i>Table of Contents</i>	(see 6.1.3)
	Foreword	Text <i>Notes</i> <i>Footnotes</i>
	<i>Introduction</i>	<i>Text</i> <i>Figures</i> <i>Tables</i> <i>Notes</i> <i>Footnotes</i>
Normative general	Title	Text
	Scope	Text <i>Figures</i> <i>Tables</i> <i>Notes</i> <i>Footnotes</i>
	Normative references	References <i>Footnotes</i>
Normative technical	Terms and definitions Symbols and abbreviated terms Requirements • • • Normative annex	Text Figures Tables <i>Notes</i> <i>Footnotes</i>
Informative supplementary	<i>Informative annex</i> ^b	<i>Text</i> <i>Figures</i> <i>Tables</i> <i>Notes</i> <i>Footnotes</i>
Normative technical	Normative annex	Text Figures Tables <i>Notes</i> <i>Footnotes</i>
Informative supplementary	<i>Index</i>	(see 6.4.3)
^a Bold Type = required element; upright type = normative element; italic type = informative element. ^b Informative annexes may not contain normative elements unless these elements constitute optional provisions. For example, a test method that is optional may contain provisions.		

5.2 Descriptions and numbering of divisions and subdivisions

5.2.1 Parts

A part is one of a series of documents published separately under the same standard number.

The number of a part shall be indicated by arabic numerals, beginning with 1, following the standard number and preceded by a hyphen, e.g., 9999-1, 9999-2, etc.

The title of a part shall be composed in the same way as that of a normal standard, as described in 6.1.1. All the individual titles in a series of parts shall contain the same introductory element (if present) and main element, while the complementary element shall be different in each case in order to distinguish the parts from one another. The complementary element shall be preceded in each case by the designation “part” followed by its number.

If a standard is published in the form of a number of separate parts, the first part shall include in its foreword (see 6.1.4) an explanation of the intended structure. In the foreword of each part belonging to the series, a reference shall be made to the titles of all other parts, if they are known.

5.2.2 Sections

For practical reasons it may be desirable to subdivide a lengthy standard, or a lengthy part of a standard, into sections. In such cases, the sections shall be numbered with arabic numerals, beginning with 1. The numbers of the clauses within a section shall include, as their first numeral, the number of the section; e.g., clauses in section 2 would be numbered 2.1, 2.2, 2.3, etc.

Each section shall begin at the top of a right-hand page. The title shall be centered and laid out as in the following example:

SECTION 1: SYMBOLS FOR QUANTITIES AND THEIR UNITS

5.2.3 Clauses

A clause is the basic component in the subdivision of the text of a standard.

The clauses in each standard or part shall be numbered with arabic numerals, beginning with 1 for the “Scope” clause. The numbering shall be continuous up to but excluding any annexes (see 5.2.7). For the numbering of clauses within sections, see 5.2.2.

Each clause shall have a title, placed immediately after its number, on a line separate from the text that follows it. Very lengthy or complex documents may be clearer in presentation if the clause number and title are separated from the text by horizontal ruled lines, above and below, as used in this document.

5.2 Descriptions and numbering of divisions and subdivisions (cont'd)

5.2.4 Subclauses

A subclause is a numbered subdivision of a clause, the number being expressed in arabic numerals (see annex F for examples). A primary subclause (e.g., 5.1, 5.2, etc.) may be subdivided into secondary subclauses (e.g., 5.1.1, 5.1.2, etc.), and this process of subdivision may be continued as far as the fifth level (e.g., 5.1.1.1.1.1, 5.1.1.1.1.2, etc.). The period serves merely as a separator and is not a decimal point.

Numbering shall not be used to create a subclause unless there is at least one further subclause at the same level. For example, a piece of text in clause 10 shall not be designated subclause “10.1” unless there is also a subclause 10.2.

Each primary subclause should preferably be given a title, which shall be placed immediately after its number, on a line separate from the text that follows it. Secondary subclauses may be treated in the same way. Within a clause or subclause, the use of titles shall be uniform for subclauses at the same level; e.g., if 10.1 has a title, 10.2 shall also have a title. In the absence of titles, key terms or phrases (composed in distinctive type) appearing at the beginning of the text of the subclause may be used to call attention to the subject matter dealt with. For examples, see 6.6.7.1 through 6.6.7.6. Such terms or phrases shall not be listed in the table of contents.

5.2.5 Paragraphs

A paragraph is an unnumbered subdivision of a clause or subclause. For example 5.2.4 comprises three paragraphs.

ISO/IEC Directive 3 prohibits the inclusion of text in any but the lowest-level subclauses of international standards. This prohibition is not maintained by this manual for EIA publications; however, the practice of including text in higher-level paragraphs is not recommended because of the ambiguity in references that is likely to result. For example, if text is included in clause 5 preceding 5.1, a reference to clause 5 that is intended to include any of its subclauses must be written as “clause 5 (including its subclauses)” or “clause 5 through subclause 5.1.3” or whatever applies. Similarly, the text in clause 5 that precedes its subclauses may be referred to as “the text in clause 5 that precedes 5.1”. To simplify these references, it would be necessary to renumber the text as 5.1 (possibly titling it, e.g., “General”) and then renumber existing 5.1 and subsequent subclauses, or to move the text elsewhere.

5.2 Descriptions and numbering of divisions and subdivisions (cont'd)

5.2.6 Lists

When the introduction to a list could stand alone as a sentence and the items in the list are not sentences, the introduction shall be followed by a colon with the items separated by semicolons (see example 1).

When the introduction to a list could stand alone as a sentence and the items in the list could also stand alone as sentences, (1) the introduction and each item shall be written as sentences (see example 2) or (2) the introduction shall be followed by a colon with the items separated by semicolons (see example 2, first list item).

When the introduction to a list cannot stand alone as a sentence, it will generally be followed by no punctuation (as in example 3, below), or by a comma when called for (as in 6.4.2.3), with the listed items separated by commas.

Each item in a list shall be preceded by an em dash or a bullet or, if necessary for identification, by a lowercase letter followed by a parenthesis. If it is necessary to further subdivide an item in the latter type of list, arabic numerals each followed by a parenthesis shall be used (see example 2).

In all cases, lists shall end with a period.

EXAMPLE 1 No switch is required for any of the following categories of apparatus:

- apparatus having a power consumption not exceeding 10 W under normal operating conditions;
- apparatus having a power consumption not exceeding 50 W, measured two minutes after the application of any of the fault conditions;
- apparatus intended for continuous operation.

EXAMPLE 2 The following requirements apply to the preparation and submission of the reports.

- a) The reports shall be **submitted by the required dates** unless arrangements are agreed upon for later submission:
 - 1) reports on failures occurring in January through June are due by the following first day of August;
 - 2) reports on failures occurring in July through December are due by the following first day of February.
- b) The reports shall be **certified** by the manager of the organization that performed the tests of the failed parts.
- c) The reports shall be **organized** as specified in annex Z. This means that reports organized under previous rules will no longer be acceptable.

5.2 Descriptions and numbering of divisions and subdivisions (cont'd)

5.2.6 Lists (cont'd)

EXAMPLE 3 Vibrations in the apparatus may be caused by

- unbalance in the rotating elements,
- slight deformation in the frame,
- the roller bearings, and
- aerodynamic loads.

Key terms or phrases may be composed in distinctive type to call attention to the subject matter dealt with in the various list items (e.g., see example 2 above and 6.1.1). Such terms or phrases shall not be listed in the table of contents. If it is necessary that these terms or phrases be listed in the table of contents, they shall be presented as subclause titles (see 5.2.4) rather than as list items.

5.2.7 Annexes

For the description of the two types of annexes, see 6.3.8 and 6.4.1.

Annexes shall appear in the order in which they are cited in the text. Each annex shall be designated by a heading comprising the word “Annex” followed by a capital letter designating its serial order, beginning with “A” but omitting “I” and “O”, e.g., “Annex A”. The annex heading shall be followed by the indication “(normative)” or “(informative)”, and by the title, each on a separate line. Numbers given to the clauses, subclauses, tables, figures, and equations of an annex shall be preceded by the letter designated to that annex followed by a period. The numbering shall start afresh with each annex. A single annex shall be designated “Annex A”.

EXAMPLE Clauses in annex A are designated “A.1”, “A.2”, “A.3”, etc.

5.2.8 Bibliography

A bibliography, if present, shall appear after the last annex. For the drafting rules, see 6.4.2.

5.2.9 Index

An index, if present, shall appear as the last element. For the drafting rules, see 6.4.3.

6 Drafting

6.1 Preliminary informative elements

6.1.1 Cover

The cover page shall contain the title of the standard and a reference number. The wording of the title shall be established with the greatest care. It shall indicate, with neither ambiguity nor unnecessary detail, the subject matter of the standard in such a way as to distinguish it from that of other standards. Any necessary additional particulars shall be given in the scope.

The title shall be composed of separate elements, each as short as possible, proceeding from the general to the particular. In general, not more than the following three elements shall be used:

- a) an *introductory element* (optional) indicating the general field to which the standard belongs (this can often be based on the title of the committee);
- b) a *main element* (required) indicating the principal subject treated within that general field;
- c) a *complementary element* (optional) indicating the particular aspect of the principal subject or giving details that distinguish the standard from other standards or from other parts of the same standard.

The title shall appear on the front cover and at the top of the page following the inside front cover. The rules in annex H for the drafting of titles have governed the titling of international standards for many years and shall be applied to all new EIA publications.

6.1.2 Notice and statement outlining similarities with non-EIA standards

The EIA Technology Strategy and Standards Department Publications Office will provide the official notice that appears on the inside front cover of all published EIA documents. Other information may also be included.

During development of a standard, the formulating committee or working group shall conduct a review and compare the standard with any related non-EIA standards such as those from the International Electrotechnical Commission (IEC), International Organization for Standardization (ISO), Electronic Industries Association of Japan (EIAJ), etc. EIA standards should agree technically with these non-EIA standards, especially international standards, unless there are valid technical reasons why this is not possible. Once this review has been completed, the chair should select the one paragraph of the following five that most nearly expresses the extent to which the standard agrees with a similar non-EIA standard. The wording may be modified if necessary to achieve an accurate statement. This information is useful to U.S. users of EIA standards as well as to the cognizant U.S. Technical Advisory Group for international standards. The paragraph selected will appear on the inside front cover of the completed EIA standard following the official notice.

6.1 Preliminary informative elements (cont'd)

6.1.2 Notice and statement outlining similarities with non-EIA standards (cont'd)

- a) “This standard is based upon the major technical content of [International Electrotechnical Commission, International Organization for Standardization, or Electronic Industries Association of Japan] standard [number], [title], [date]. It conforms in all essential respects with this [IEC, ISO, or EIAJ] standard.”
- b) “This standard contains the major technical contents of [International Electrotechnical Commission, International Organization for Standardization, or Electronic Industries Association of Japan] standard [number], [title], [date]. It differs from [IEC, ISO, or EIAJ] standard [number] in certain important respects, as given in annex A hereto. These differences have been called to the attention of the U.S. National Committee of the [IEC or ISO] Technical Committee [number], [title], [date], and resolution of these differences will be sought in future meetings of [TC number or EIA number].”
- c) “This standard was developed by EIA Committee [number] after consideration of the contents of the latest draft of the [International Electrotechnical Commission, International Organization for Standardization, or Electronic Industries Association of Japan] [document or standard] [number], [title], [date] covering this subject. This standard does not agree with [IEC, ISO, or EIAJ] [document or standard] [number]. The important differences that made reconciliation of the two documents impossible are given in annex A. These differences have been called to the attention of the U.S. National Committee of the [IEC or ISO].”
- d) “This EIA standard is considered to have international standardization implications, but the [International Electrotechnical Commission, International Organization for Standardization, or Electronic Industries Association of Japan] activity has not progressed to the point where a valid comparison between the EIA standard and the [IEC, ISO, or EIAJ] document can be made.”
- e) “This EIA standard is considered by the formulating committee not to have international standards implications or interest.”

6.1.3 Table of contents

A table titled “Contents” shall be included in all documents of ten pages or more. Its inclusion in shorter documents is optional. This table shall list (as appropriate), in the following order, the complete titles of sections, clauses, the first series of subclauses, annexes together with their status (normative or informative) in parentheses and their clauses and first-series subclauses, the bibliography, index, figures, and tables. Additional levels of subclauses may be included, but in no case shall there be more than one level of indentation. See “Contents” in this manual as an example. Terms in a “Terms and definitions” clause shall not be listed in the table of contents.

6.1 Preliminary informative elements (cont'd)

6.1.4 Foreword

A foreword shall appear in each standard. It shall not contain requirements, figures, or tables. The foreword consists of a general part giving information relating to the organization responsible and to standards in general, and a specific part giving as many of the following as are appropriate:

- an indication of the intended user of the document;
- the designation and name of the committee that prepared the standard;
- information regarding the approval of the standard by the Engineering Department Executive Committee (EDEC);
- an indication of any other organization that has contributed to the preparation of the standard;
- a statement that the standard cancels and replaces other documents in whole or in part;
- a statement of significant technical changes from the previous edition of the standard;
- the relationship of the standard to other standards or other documents;
- a statement as to which annexes are normative and which are informative.

6.1.5 Introduction

The introduction is an optional preliminary element that may be used to give specific information or commentary about the technical content of the standard and about the reasons prompting its preparation. It shall not contain requirements.

The introduction shall not be numbered unless there is a need to create numbered subdivisions. In this case, it shall be numbered 0 with subclauses numbered 0.1, 0.2, etc. Any numbered figure, table, displayed formula, or footnote shall be numbered normally beginning with 1.



6.2 General normative elements

6.2.1 Scope

A statement of scope states what is and, if appropriate, what is not covered by the document, and the intended applications or purpose of the document. The scope of the document shall not exceed the approved scope of the formulating committee or working group.

This element shall appear in every standard. It shall not contain requirements. It shall be succinct so that it can be used as a summary for bibliographic purposes.

This element shall be worded as a series of statements of fact. Forms of expression such as the following shall be used:

- “This standard
- specifies 
 - the dimensions of ...”
 - a method ...”
 - the characteristics of ...”
 - establishes 
 - a system for ...”
 - general principles for ...”
 - defines terms ...”

Statements of applicability of the document shall be introduced by the following wording:

“This standard [publication, etc.] is applicable to ...”

6.2 General normative elements (cont'd)

6.2.2 Normative references

This optional element shall give a list of normative documents to which reference is made (see 6.6.6.5) in the standard in such a way as to make them indispensable for the application of the standard. For dated references, each shall be given with its full title and year of publication, or, in the case of drafts, with its full title and a dash together with a footnote "To be published." The year of publication or dash or revision indicator shall not be given for undated references. When an undated reference applies to all parts of a publication, the publication number shall be followed by the indication "(all parts)" and the general title of the series of parts (i.e., the introductory and main elements); see annex H.

EXAMPLE 1

EIA/JEDEC JESD22-A110-A, *Highly accelerated temperature and humidity stress test (HAST)*, April 1997.

EXAMPLE 2

EIA/JEDEC JEP95 - (all parts), *JEDEC registered and standard outlines for solid state and related products*.

EXAMPLE 3

EIA/JEDEC JESD30-M, *Descriptive designation system for semiconductor-device packages,—²⁾*.
•
•
•

2) To be published.

Generally, the normative documents shall be standards published by EIA or its sectors. Normative documents published by other bodies may be listed provided that

- the document is recognized by the committee concerned as having wide acceptance and authoritative status as well as being publicly available, and
- the committee concerned undertakes to review the situation in the light of any subsequent changes in the referenced document.

6.2 General normative elements (cont'd)

6.2.2 Normative references (cont'd)

The list shall be introduced by the following wording:

“The following normative documents contain provisions that, through reference in this text, constitute provisions of this standard. For dated references, subsequent amendments to, or revisions of, any of these publications do not apply. However, parties to agreements based on this standard are encouraged to investigate the possibility of applying the most recent editions of the normative documents indicated below. For undated references, the latest edition of the normative document referred to applies.”

The list shall not include the following:

- documents that are not publicly available;
- documents to which only informative reference is made; or
- documents that have merely served as references in the preparation of the standard.

Such documents may be listed in an informative annex (see 6.4.1) entitled “Bibliography” (see 6.4.2).

6.3 Technical normative elements

6.3.1 Terms and definitions

This is an optional element giving definitions necessary for the understanding of certain terms used in the standard. The following introductory wording, modified as appropriate, shall be used:

“For the purposes of this standard, the terms and definitions given in ... and the following apply:”

Rules for the drafting and presentation of terms and definitions are given in annex G.

6.3 Technical normative elements (cont'd)

6.3.2 Symbols and abbreviated terms

This is an optional element giving a list of the symbols and abbreviated terms necessary for the understanding of the standard.

Unless there is a need to list symbols in a specific order to reflect technical criteria, all symbols should be listed in alphabetical order in the following sequence:

- uppercase Latin letter followed by lowercase Latin letter (*A, a, B, b*, etc.);
- letters without indices preceding letters with indices, and with letter indices preceding numerical ones (*B, b, C, C_m, C₂, c, d, d_{ext}, d_{int}, d₁*, etc.);
- Greek letters following Latin letters (*Z, z, A, a, B, β, …, Λ, λ*, etc.); and
- any other special symbols.

For convenience, this element may be combined with element 6.3.1 in order to bring together terms and their definitions, symbols, abbreviated terms and perhaps units under an appropriate composite title, for example, “Terms, definitions, symbols, units, and abbreviated terms”.

6.3.3 Requirements

This element is optional. If present, it shall contain the following:

- all characteristics relevant to the aspects of the products, processes, or services covered by the standard, either explicitly or by reference;
- the required limiting values of quantifiable characteristics;
- for each requirement, either the test method for determining or verifying the values of the characteristic (see 6.3.5), or a reference to the test method;
- precautions to be observed;
- allowable variations and quality or reliability information; and
- other technical requirements.

A clear distinction shall be made between requirements, statements, and recommendations.

Contractual requirements concerning claims, covering of expenses, etc., shall not be included.

6.3 Technical normative elements (cont'd)

6.3.3 Requirements (cont'd)

In some product standards, it may be necessary to specify that the product shall be accompanied by warning notices, caution notices, or instructions to the user or installer. These product standards shall also specify the content of such notices and instructions. Specific requirements concerning use or installation as such shall be included in a separate standard because they are not requirements applicable to the product itself.

Standards listing characteristics for which suppliers are required to state values that are not specified by the standard itself shall specify how the values are to be measured and stated.

Legal limitations on expressions of quality or reliability requirements are found in EIA Legal Guides. If detailed requirements are listed elsewhere in the document or in detail sheets, reference to these subsections or sheets should be made in this element.

6.3.4 Sampling

This optional element specifies the conditions and methods of sampling, as well as the method for the preservation of the samples. This element may appear at the beginning of element described in 6.3.5.

6.3.5 Test methods

Whenever possible, test methods and procedures specified in EIA or its sectors, IEEE, or ANSI standards shall be cited. Otherwise, this optional element gives all the instructions concerning the procedure for determining the values of characteristics, or for checking compliance with stated requirements, and for ensuring the reproducibility of the results. If appropriate, tests shall be identified to indicate whether they are type tests, routine tests, sampling tests, and so on.

Instructions relating to the test methods may be subdivided in the following order (where appropriate):

- underlying principles;
- reagents or materials;
- apparatus;
- preparation and preservation of test samples and test pieces;
- procedure;
- expression of results, including method of calculation and precision of the test method;
- test report.

Test methods may be presented as separate clauses, annexes (see 6.3.9), or separate parts (see 5.2.1), or be incorporated in the element described in 6.3.3. A test method shall be prepared as a separate standard if it is likely to be referred to in a number of other standards.

6.3 Technical normative elements (cont'd)

6.3.6 Classification and designation

This optional element may establish a system of classification, designation, and/or coding of products, processes, or services that conform to stated requirements. For convenience, this element may be combined with the element described in 6.3.3.

6.3.7 Marking, labeling, and packaging

This optional element may specify the marking of a product (e.g., manufacturer's or vendor's trademark, model, or type number). It may include requirements for the labeling and/or packaging of the product (e.g., handling instructions, hazard warnings, date of manufacture as appropriate).

Symbols specified for marking shall be in conformity with relevant standards.

The elements described in 6.3.6 and 6.3.7 may be supplemented by an informative annex giving an example of ordering information.

6.3.8 Application notes

Miscellaneous items not readily included elsewhere may be listed in this optional element.

6.3.9 Normative annexes

Normative annexes are integral parts of the standard that, for reasons of convenience, are placed after all other normative elements. Their presence is optional. The fact that an annex is normative (as opposed to informative — see 6.4.1) shall be made clear by the way in which it is referred to in the text, by a statement to this effect in the foreword (see 6.1.4), and by an indication in the table of contents and under the heading of the annex itself.

6.4 Supplementary informative elements

6.4.1 Informative annexes

Informative annexes (formerly called appendixes) give additional information intended to assist the understanding or use of the standard and shall not contain provisions to which it is necessary to conform in order to be able to claim compliance with the standard. Their presence is optional. The informative (as opposed to normative — see 6.3.9) status of an annex shall be made clear by the way in which it is referred to in the text, by a statement to this effect in the foreword (see 6.1.4), and by an indication in the table of contents and under the heading of the annex itself.

6.4 Supplementary informative elements (cont'd)

6.4.2 Bibliographic references

6.4.2.1 General

Supply complete, up-to-date references to articles in periodicals and books, etc., as outlined in 6.4.2.2, 6.4.2.3, and 6.4.2.4. Do not cite documents that are no longer readily available.

Informative references may be gathered into a numbered list in an informative annex, called “Bibliography”, in the supplementary matter. See 5.2.8. The entries are usually listed in the order of citation in the text. In the text, the reference indicator is a number in brackets set on the text line. Alternatively, the informative references may be given as footnotes (see 6.5.2).

Place mandatory references stated in terms of “shall” requirements (see annex J) in the text of the document and not in a footnote or bibliographic section (see also 6.2.2). The footnotes and the bibliography are not an official part of the document.

6.4.2.2 References to articles in periodicals

References to articles in periodicals should include, in the following order,

- name of author (if in a footnote form, exactly as it appears in the heading of the article; if in a bibliography, last name first but only for the first author if there are two; when there are three or more authors, list only the first author’s name followed by “et al.” meaning “and others”),
- title of article (in quotation marks),
- title of periodical (in italics; title of professional journals are frequently abbreviated),
- volume number (if given),
- issue number (if given),
- date of issue, and
- first and last page numbers of article.

EXAMPLE In a bibliography

5. Roshen, W.A., and D.E. Turcotte, “Planar Inductors on Magnetic Substrates”, *IEEE Trans. Magn.*, Vol. 24, No. 6, November 1988, pp. 3213-3216.

6.4 Supplementary informative elements (cont'd)

6.4.2 Bibliographic references (cont'd)

6.4.2.3 References to books

References to books should include, in the following order,

- name of author (if in footnote form, exactly as it appears in the heading of the article; if in a bibliography, last name first but only for the first author if there are two; when there are three or more authors, list only the first author's name followed by “et al.” meaning “and others”),
- name of editor or editors (if given in place of author) followed by “(ed.)” or “(eds.)” if plural,
- title of book (in italics),
- volume number (preceded by “Vol.,” “Part” or whatever the actual designation is), when accompanied by the title (in italics) of the volume or part,
- edition number (if not the first edition),
- name of publisher,
- place of publication,
- year of publication,
- volume number (if given without volume title),
- chapter number and chapter title (only if considered significant), and
- first and last page numbers of reference.

EXAMPLE 1 In a bibliography

7. Feigenbaum, A.V., *Total Quality Control*, 3rd ed., McGraw-Hill Book Company, New York, 1983, pp. 109–145.

EXAMPLE 2 In a footnote

10) R.R. Tummala and E.J. Rymaszewski (eds.), *Microelectronics Packaging Handbook*, Van Nostrand Reinhold, New York, 1989, pp. 71–78.

6.4 Supplementary informative elements (cont'd)

6.4.2 Bibliographic references (cont'd)

6.4.2.4 References to technical reports, patents, conference records, etc.

Other references should be handled giving the same information (to the extent applicable) as has been detailed in 6.4.2.2 for periodicals and/or 6.4.2.3 for books.

EXAMPLE 1 A reference to a technical report shown in a bibliography

3. Surface Mount Council, *An Introduction to Tape Automated Bonding and Fine Pitch Technology*, SMC-TR-001, Lincolnwood, IL, January 1989

EXAMPLE 2 A reference to a patent shown in a bibliography

4. Iwasaki, Y., "Projection Cathode-Ray Tube", U.S. Patent 5,177,400, January 5, 1993.

EXAMPLE 3 A reference to a selection from an anthology shown in a footnote

26) G.J. Ewell, "Evaluation of Methods for Performing Adhesion Measurements of Thick-Film Terminations on Chip Components", in K.L. Mittal, ed., *Adhesion Measurement of Thin Films, Thick Films, and Bulk Coatings*, American Society for Testing Materials, Philadelphia, 1978, pp. 251–268.

EXAMPLE 4 A reference to a paper in a conference record shown in a footnote

12) D.D. Chang et al., "Accelerated Life Test of Z-Axis Conductive Adhesives", *Proc. 43rd Electronic Components and Technology Conference*, EIA and IEEE/CHMT, Orlando, 1993, pp. 211–217.

6.4.3 Index

It is desirable that an index be provided for documents that are very long or complex. Prepare the index in accordance with the recommendations in ANSI Z39.4.

6.4.4 Related EIA documents

List the number and title of all EIA documents whose content is closely related to the proposed document. This information shall appear on the inside back cover of the printed document.

6.5 Other informative elements

6.5.1 Notes and examples integrated into the text

Notes and examples integrated into the text of a standard shall be used only for giving additional information intended to assist in understanding or using the standard and shall not contain provisions to which it is necessary to conform in order to be able to claim compliance with the standard.

Notes and examples should preferably be placed at the end of the clause or subclause or after the paragraph to which they refer.

A single note in a clause or subclause shall be preceded by “NOTE”, placed at the beginning of the first line of the text of the note. When several notes occur within the same clause or subclause, they shall be designated “NOTE 1”, “NOTE 2”, “NOTE 3”, etc.

All lines of a note shall be indented relative to the text to which the note applies or aligned with that text and set in smaller type (see 7.3.4) so that the extent of the note can be correctly understood.

A single example in a clause or subclause shall be preceded by “EXAMPLE”, usually placed at the beginning of the first line of the text of the example. When several examples occur within the same clause or subclause, they shall be designated “EXAMPLE 1”, “EXAMPLE 2”, “EXAMPLE 3”, etc.

Normally, examples are not indented. However, so that the extent of a complicated example can be correctly understood, the entire example may be indented as in G.1.4.8 and G.3.4.

6.5.2 Footnotes to the text

Footnotes to the text give additional information, but their use shall be kept to a minimum. They shall not contain requirements. Footnotes to figures and to tables follow different rules (see 6.6.4.9 and 6.6.5.7).

Footnotes to the text shall be placed at the foot of the relevant page and be separated from the text by a thin horizontal line that starts at the left margin and has a length of approximately 50 mm (2 inches).

Footnotes to the text shall normally be distinguished by arabic numerals, beginning with 1, followed by one parenthesis: 1), 2), 3), etc., forming a continuous numerical sequence throughout the document or starting afresh on each page. (The former method is more suited to documents produced using computer-aided text processing systems.) The footnotes shall be referred to in the text by inserting the same numerals, as superscripts, after the word or sentence in question: ¹⁾, ²⁾, ³⁾, etc. In certain cases, for example in order to avoid confusion with exponents, use the following symbols (as available) in this order: *, †, ‡, §, ¶, #, **, ††, ‡‡, §§, ¶¶, ##, ***, etc. If the footnote reference comes at the end of a sentence, it should follow any mark of punctuation.

6.6 Common rules and elements

6.6.1 Verbal forms for the expression of provisions

A standard does not in itself impose any obligation upon anyone to follow it. However, such an obligation may be imposed, for example, by legislation or by a contract. In order to be able to claim compliance with a standard, users must be able to identify the requirements they are obligated to satisfy. They must also be able to distinguish these requirements from other provisions where there is a choice. Clear rules for the use of verbal forms (including auxiliary verbs, e.g., “shall” and “will”) are therefore essential.

Annex J gives, in the first column of each table, the verbal form that shall be used to express each kind of provision. The equivalent expressions given in the second column shall be used only in exceptional cases when the form given in the first column cannot be used for linguistic reasons.

6.6.2 Spelling, abbreviations, style, and grammar

6.6.2.1 Dictionaries and spelling

Use *Webster’s Third New International Dictionary, Unabridged* or *Merriam-Webster’s Collegiate Dictionary, Tenth Edition*, as the guide to correct spelling. If more than one spelling is given, the form printed first is preferred in most cases. Annex K lists some words that are frequently misspelled or misused in technical documents.

NOTE 1 Do not rely solely on computerized programs to check spelling or hyphenation (see 6.6.2.4). Spelling and usage errors such as “there” for “their” and “to” for “too” will escape detection in the absence of human intervention.

NOTE 2 When an EIA standard is submitted to the International Electrotechnical Commission (IEC) for acceptance as an international standard, the IEC will normally convert the spelling and punctuation to comply with the (British) Oxford dictionary.

The spelling of the names of organizations and their abbreviations shall be as used by those organizations.

6.6.2.2 Abbreviations and acronyms

Use technical abbreviations and acronyms only if necessary to enhance recognition or save space and only if their meaning is unquestionably clear to the intended reader.¹⁾ If in doubt, spell out the word or words in full when first used, with the abbreviation or acronym following in parentheses.

Abbreviations should conform to recognized standards such as ANSI/ASME Y1.1. Annex L lists the more common abbreviations from ANSI/ASME Y1.1 used in the electronics industry.

If an abbreviation that consists exclusively of letters normally written in lowercase letters (e.g., ac, dc, rms) begins a sentence or appears in a heading or title whose major words are initially capitalized or all-uppercase, all letters of the abbreviation shall be capitalized. However, abbreviations that also happen to be unit symbols (e.g., mm) are never changed.

1) An abbreviation is a shortened form of a word or phrase (e.g., max for maximum). An acronym is a word formed from the initial letter(s) of successive parts of a term (e.g., laser, radar, BiMOS, and COBOL).

6.6 Common rules and elements (cont'd)

6.6.2 Spelling, abbreviations, style, and grammar (cont'd)

6.6.2.2 Abbreviations and acronyms (cont'd)

Do not use periods with technical abbreviations,¹⁾ and do not add “s” to an abbreviation that ends in a lowercase letter to indicate the plural. For example, use ac, dc, rms, 17.8 lb (not lbs), 2.5 cm, 6.83 in, 24 h. If using “in” for inch or inches leads to confusion, spell it out rather than use a period; e.g., 6.83 inches, 0.83 inch.

Do not use periods within acronyms. Plurals of abbreviations that end with an uppercase letter and most acronyms shall be formed by the addition of a lowercase “s” with no apostrophe (e.g., ICs, ROMs, lasers); however, plurals of acronyms ending in “S” or “s” shall be formed by the addition of a lowercase “s” preceded by an apostrophe (e.g., MEMS's).

6.6.2.3 Style

To facilitate understanding by all readers, the style shall be as clear and concise as possible. This is particularly important for those readers whose native language is not English.

6.6.2.4 Compound words and hyphenation

6.6.2.4.1 General

Consult ANSI/IEEE Std 100, *IEEE Standard Dictionary of Electrical and Electronics Terms*, or *Merriam-Webster's New Collegiate Dictionary, Tenth Edition* on the question of whether a compound word should be hyphenated or presented as one or two words (e.g., field-test, fieldtest, or field test). Compound words not found in a dictionary should be presented in the form that minimizes ambiguity.

6.6.2.4.2 Prefixes

In American practice, prefixes usually do not require a hyphen unless the resulting combination would form a word other than the one intended (e.g., un-ionized; re-form, meaning to form again). Typical combinations that are correctly used as a single word include electromechanical, antistatic, electrostatic, nonhermetic, nonrepetitive, preadjustment, subclause, and subcommittee. British practice, which is followed by IEC, makes much more frequent use of hyphens.

6.6.2.4.3 Compound adjectives

A hyphen should generally be used between two or more words that serve as a single adjective before a noun unless the first word is an adverb ending in “ly”, e.g., small-signal gain (gain under small-signal conditions) contrasted with small signal gain (not much signal gain).

1) The nonuse of periods with technical abbreviations is the long-standing practice of EIA and IEEE. This is in conflict with the European practice reflected in IEC practice. According to IEC, the general rule is that abbreviations consisting of the initial letters of words be printed in lowercase letters with a period after each letter (e.g., “a.c.” for “alternating current”).

6.6.2 Spelling, abbreviations, style, and grammar (cont'd)

6.6.2.4 Compound words and hyphenation (cont'd)

6.6.2.4.4 Word division

When dividing a word between the end of one line of text and the beginning of another, hyphenate between syllables according to pronunciation rather than derivation. If in doubt, consult *Webster's Third New International Dictionary, Unabridged* or *Merriam-Webster's Collegiate Dictionary, Tenth Edition*. Avoid separating a single letter as in a-symmetry or criteri-a.

NOTE Do not rely solely on computerized programs to check spelling (see 6.6.2.1) or hyphenation.

6.6.2.4.5 Hyphens and dashes

If equipment permits a choice between hyphens and dashes,

- the hyphen (-) shall be used for hyphenation of words (e.g., un-ionized) and in complex symbols (e.g., $t_{A(BC-DEF)}$),
- the “en” dash (–) shall be used to indicate a negative quantity or subtraction (e.g., $-40\text{ }^{\circ}\text{C}$ or $9 - 5 = 4$) and to indicate “through” (e.g., pp 2–5), and
- the “em” dash (—) may be used to punctuate displayed lists as illustrated here and described in 5.2.6.

6.6.2.5 Widows and orphans

Avoid widows and orphans; i.e., do not allow the first line of a paragraph to be the final line on a page, or the last line of a paragraph to head a new page. Similarly, do not allow headings of clauses or subclauses to occur as the final line of a page.

6.6.2.6 Capitalization

Overuse of capitals can obscure meaning and reduce readability. Do not capitalize for emphasis; use bold type, italics, or underlining instead.

Use all capitals (entirely uppercase) for axis labels on graphs (except for units and symbols, whose capitalization is determined by applicable standards).

Use sentence-style capitalization (initial capital for only the first word and for proper nouns and proper adjectives) for all titles of standards, parts, clauses, subclauses, figures, tables, and table elements (see 6.6.5.8).

6.6 Common rules and elements (cont'd)

6.6.2 Spelling, abbreviations, style, and grammar (cont'd)

6.6.2.7 “That” and “which”

The word “that” is used to introduce a restrictive clause, i.e., a clause that is required to identify the noun it modifies. The word “that” is not preceded by a comma when it directly follows the modified noun. Definitions usually use restrictive clauses.

The word “which” is used to introduce a nondefining or parenthetical clause, i.e., a clause that only adds information about a subject already identified. The word “which”, when used in this sense, is preceded by a comma.

For example:

Restrictive

“The version of the device that is in a surface-mounted package allows increased component density.”

Nonrestrictive

“The new version of the device, which is in a surface-mounted package, allows increased component density.”

6.6.2.8 Frequently misused words and phrases

Certain errors in word use frequently appear in technical publications. Annex K lists a number of commonly misused words and phrases.

6.6.3 Trade names, patents, and copyrights

6.6.3.1 Trade names

A correct designation or description of a product shall be given rather than a trade name (brand name).

Proprietary trade names (i.e., trademarks) for a particular product should, insofar as possible, be avoided, even if they are in common use.

EXAMPLE Instead of “Teflon®”, write “polytetrafluoroethylene (PTFE)”.

If, exceptionally, trade names cannot be avoided, their nature shall be indicated by the symbol TM for a trademark, ® for a registered trademark, © for a copyright, or SM for a service mark. An appropriate explanation shall be given as described in the following paragraphs.

If it is known that only one product is currently available that is suitable for the successful application of the standard, the trade name of the product may be given in the text of the standard, with the following footnote:

“[Trade name of product] is the trade name of a product supplied by [supplier]. This information is given for the convenience of users of this standard and does not constitute an endorsement by [EIA or ANSI] of the product named. Equivalent products may be used if they can be shown to lead to the same results.”

6.6.3 Trade names, patents, and copyrights (cont'd)

6.6.3.1 Trade names (cont'd)

If it is considered to be essential to give an example of commercially available products suitable for successful application of the standard because the product characteristics are difficult to describe in detail, trade names may be given in a footnote as follows:

“[Trade names of products] are examples of suitable products available commercially. This information is given for the convenience of users of this standard and does not constitute an endorsement by [EIA or ANSI] of these products.”

6.6.3.2 EIA and ANSI patent policies

In general, EIA and ANSI have similar patent policies. Both EIA and ANSI patent policies were designed to balance the rights of the patent holder to exploit its legal monopoly in connection with its technology and the rights of users of the standard to have access to technology that is essential to implement the standard. EIA and patent holders both have responsibilities in connection with EIA's and ANSI's patent policies. EIA shall respond to any assertion by a patent holder, request that the holder state definitively by a specified date whether the holder's technology is “essential”, and if so, ask if the holder is willing to license the technology on reasonable terms and conditions.

There is no objection in principle to drafting a proposed EIA or ANSI standard in terms that include the use of a patented item, if it is considered that technical reasons justify this approach. If the formulating group receives notice that a proposed standard may require the use of a patented invention, an EIA staff representative must receive from the patent holder, prior to approval,

- a) assurance in the form of a general disclaimer to the effect that the patentee does not hold and does not anticipate holding any invention whose use would be required for compliance with the proposed standard,
- b) assurance that a license will be made available without compensation to applicants desiring to utilize the license for the purpose of implementing the standard, or
- c) assurance that a license will be made available to applicants under reasonable terms and conditions that are demonstrably free of any unfair discrimination.

When the formulating group receives from a patent holder the assurance set forth in b) or c) above, the standard shall include a note as follows:

“NOTE The user's attention is called to the possibility that compliance with this standard may require use of an invention covered by patent rights.

“By publication of this standard, no position is taken with respect to the validity of this claim or of any patent rights in connection therewith. The patent holder has, however, filed a statement of willingness to grant a license under these rights on reasonable and nondiscriminatory terms and conditions to applicants desiring to obtain such a license. Details may be obtained from the publisher.”

6.6.3 Trade names, patents, and copyrights (cont'd)

6.6.3.2 EIA and ANSI patent policies (cont'd)

A patent holder is not required, under any circumstances, to permit the use of its technology for free or on reasonable terms and conditions. If the patent holder chooses not to make its technology available and the technology is essential to implementation of the EIA and/or ANSI/EIA standard, then it may be necessary to revise or withdraw the standard.

6.6.3.3 Copyrighted material

If, in developing a standard, a formulating group proposes to incorporate verbatim material from a publication copyrighted by another entity, it shall obtain written permission from the owner of the copyright for EIA to reprint the material, forward the letter granting permission directly to the EIA Technology Strategy and Standards Department, and include a reference to such permission in the standard as a footnote (see 6.5.2).

6.6.4 Figures

6.6.4.1 Usage

Figures should be used wherever appropriate to present information in an easily comprehensible form. Each figure shall be referred to explicitly in the text so that its significance in relation to the provisions of the standard is made clear.

Only one level of subdivision is permitted; e.g., Figure 1 may be subdivided as a), b), c), etc.

In the printed document, each figure should be on the page where first cited or on the next succeeding page (or on the next succeeding pages if references to several figures appear on the same page). Alternatively, figures may be placed at the end of the individual clauses or at the end of the document. For presentation of figures, see 7.2.2.

6.6.4.2 Form

Figures shall be in the form of line drawings. Photographs may be used only if it is not possible to convert them into line drawings. Prepare drawings, charts, and graphs in accordance with ANSI standards on drafting, abbreviations, letter and graphic symbols, and charts. See annex C.

It is preferable to supply computer-generated artwork provided that details have been agreed upon with the recipient. Alternatively, correctly prepared drawings, graphs, etc. may be supplied as clean black and white originals, photographic prints, or laser prints. Xerographic copies are generally not usable.

6.6.4.3 Numbering

Figures shall be numbered with arabic numerals, in the order in which they are first called out in the text, beginning with 1. Use of sequential figure numbers throughout a document (excluding its annexes — see 5.2.7) is preferred (and, for international standards, is required by IEC); however, for practical reasons, numbering of figures by section, clause, or subclause, (e.g., labeling the first figure in 3.4 as 3.4-1) is permitted in lengthy non-IEC publications. This numbering shall be independent of the numbering of tables. A single figure shall be designated “Figure 1”. Informal figures are an exception (see 6.6.4.10).

6.6 Common rules and elements (cont'd)

6.6.4 Figures (cont'd)

6.6.4.4 Layout of title

The title shall be horizontally centered below the figure and laid out as in the following example:

Figure 1 — Details of apparatus

6.6.4.5 Choice of letter symbols, style of lettering, and labeling

Letter symbols used on figures to represent general cases of angular and linear quantities shall be in accordance with ANSI/IEEE Std 260.1 and ANSI X3.50, subscripts being used where necessary to differentiate between different applications of a given symbol. For example, for a series of symbols indicating various lengths on a drawing, use l_1 , l_2 , l_3 , (see Figure 1) and not, for instance, a , b , c .

Inclined (italic) letters shall be used for

- symbols for quantities (e.g., T for temperature, t for time),
- subscripts representing symbols for quantities (e.g., L for inductance as in X_L), and
- symbols for constants (e.g., k for Boltzmann's constant).

The vertical (roman) style shall be used for all other lettering.

6.6.4.6 Technical drawing

Technical drawings shall be presented in accordance with relevant standards, including ANSI Y14.5M, ANSI/ASME Y1.1, ANSI/ASME Y14.1M, ANSI/ASME Y14.2M, ANSI/ASME Y14.3M, ANSI/ASME Y14.4M, ANSI/ASME Y14.24M, ANSI/IEEE Std 315 (section A4), and ANSI/IEEE Std 991 (section 4 and appendix B).

6.6.4.7 Diagrams

Diagrams, such as circuit diagrams and connection diagrams, for example for test circuits, shall be prepared in accordance with ANSI Y14.15 and ANSI/IEEE Std 991. Graphical symbols used in schematic diagrams shall be in accordance with ANSI/IEEE Std 315. Logic symbols shall be in accordance with ANSI/IEEE Std 91. Reference designations in diagrams shall be in accordance with ANSI/IEEE Std 200 and IEEE Std 315 (section 22). Signal designations in diagrams shall be in accordance with ANSI/IEEE Std 991.

6.6.4.8 Notes to figures

Notes to figures shall be treated independently from notes integrated into the text (see 6.5.1). They shall be located above the title of the relevant figure and shall precede figure footnotes (see following example). A single note in a figure shall be preceded by "NOTE", placed at the beginning of the first line of the text of the note. When several notes occur in the same figure, they shall be designated "NOTE 1", "NOTE 2", "NOTE 3", etc. A separate numbering sequence shall be used for each figure.

6.6 Common rules and elements (cont'd)

6.6.4 Figures (cont'd)

6.6.4.8 Notes to figures (cont'd)

Notes to figures shall not contain requirements. Any requirements relating to the content of a figure shall be given in the text, in a footnote to the figure, or as a paragraph between the figure and its title. It is not necessary that notes to figures be referred to.

EXAMPLE



A paragraph containing a requirement.

NOTE Figure note.

^a Figure footnote.

^b Figure footnote.

Figure # — Title

6.6.4.9 Footnotes to figures

Footnotes to figures shall be treated independently from footnotes to the text (see 6.5.2). They shall be located immediately above the title of the relevant figure and shall follow figure notes, if any (see example in 6.6.4.8).

Footnotes to figures shall be distinguished by superscript lowercase letters, beginning with “a”. The footnotes shall be referred to in the figure by inserting the same superscript lowercase letter after the item in question.

Footnotes to figures may contain requirements. As a consequence, it is particularly important when drafting the text of the figure footnote to distinguish between different types of provisions by using the appropriate verbal forms (see annex J).

6.6.4.10 Informal Figures

Small, simple figures, typically those that are the equivalent of not more than six lines of text, require neither figure number nor title. Such figures (see the following example) may be considered part of the text.

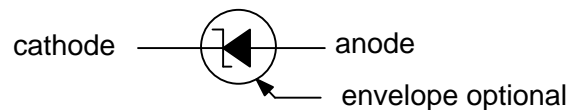

6.6 Common rules and elements (cont'd)

6.6.5 Tables

6.6.5.1 Usage

Tables provide a clear and concise way of presenting large quantities of data in a relatively small space. A simple table can often give information that would require several paragraphs of text and can do so with much greater clarity. Each table shall be referred to explicitly in the text so that its significance in relation to the provisions of the standard is made clear.

In the printed document, each table should be on the page where first cited or on the next succeeding page (or on the next succeeding pages if references to several tables appear on the same page). Tables that are short enough to fit on a single page shall not be divided onto two pages. Alternatively, tables may be placed at the end of the individual clauses or at the end of the document. For presentation of tables, see 7.2.2.

A table within a table is not permitted. Subdivision of a table into subsidiary tables is not permitted.

6.6.5.2 Numbering

Tables shall be numbered with arabic numerals, in the order in which they are first called out in the text, beginning with 1. Use of sequential table numbers throughout a document (excluding its annexes — see 5.2.7) is preferred (and, for international standards, is required by IEC); however, for practical reasons, numbering of tables by section, clause, or subclause, (e.g., labeling the first table in 3.4 as 3.4-1) is permitted in lengthy non-IEC publications. This numbering shall be independent of the numbering of figures. A single table shall be designated “Table 1”. Informal tables are an exception (see 6.6.5.9).

6.6.5.3 Layout of title

The title shall be centered horizontally above the table and laid out as in the following example:

Table 31 — Mechanical properties

6.6.5.4 Headings

The first word in the heading of each column shall begin with a capital letter. The units used in a given column shall generally be indicated at the bottom of the column heading. See example 1.

EXAMPLE 1

Type	Linear density (kg/m)	Inside diameter (mm)	Outside Diameter (mm)
------	--------------------------	----------------------------	-----------------------------

6.6.5 Tables (cont'd)

6.6.5.4 Headings (cont'd)

As an exception to this rule, when all units are the same, a suitable statement may instead be placed above the right-hand corner of the table. See example 2.

EXAMPLE 2

Dimensions in millimeters			
Type	Length	Inside diameter	Outside diameter

The presentation shown in example 3 is not permitted; that shown in example 4 is generally used instead.

EXAMPLE 3

Type	A	B	C
Dimension			

EXAMPLE 4

Dimension	Type		
	A	B	C

6.6.5.5 Continuation of tables

When a table is continued over two or more pages, the number of the table shall be repeated, followed by the title (optional) and by “(continued)” or “(cont'd)”, as in the following example:

Table 67 (continued)
or
Table 67 (cont'd)

The column headings together with any statement containing units shall also be repeated on pages after the first.

6.6.5.6 Notes to tables

Notes to tables shall be treated independently from notes integrated into the text (see 6.5.1). They shall be located within the frame of the relevant table and shall precede table footnotes (see the following example). A single note in a table shall be preceded by “NOTE”, placed at the beginning of the first line of the text of the note. When several notes occur in the same table, they shall be designated “NOTE 1”, “NOTE 2”, “NOTE 3”, etc. A separate numbering sequence shall be used for each table.

Notes to tables shall not contain requirements. Any requirements relating to the content of a table shall be given in the text, in a footnote to the table, or as a paragraph within the table. It is not necessary that notes to tables be referred to.

6.6.5 Tables (cont'd)

6.6.5.6 Notes to tables (cont'd)

EXAMPLE

Dimensions in millimeters			
Type	Length	Inside diameter	Outside diameter
	I_1^a	d_1	
	I_2	d_2^b	
A paragraph containing a requirement.			
NOTE 1 Table note.			
NOTE 2 Table note.			
^a Table footnote.			
^b Table footnote.			

6.6.5.7 Footnotes to tables

Footnotes to tables shall be treated independently from footnotes to the text (see 6.5.2). They shall be located within the frame of the relevant table and shall follow table notes (see example in 6.6.5.6).

Footnotes to figures shall be distinguished by superscript lowercase letters, beginning with “a”, unless confusion is likely. In that case, use the following symbols (as available) in this order: *, †, ‡, §, ¶, #, **, ††, ‡‡, §§, ¶¶, ##, ***, etc. The footnotes shall be referred to in the table by inserting the same letters (superscripted and lowercase) or symbols. Place these note reference indicators in the table beginning at the upper left and extending first horizontally across the table, then vertically downward, row by row. These may be placed as shown in the example or in a separate column labeled “footnotes”.

Footnotes to tables may contain requirements. As a consequence, it is particularly important when drafting the text of the table footnote to distinguish between different types of provisions by using the appropriate verbal forms (see annex J).

6.6.5 Tables (cont'd)

6.6.5.8 Format and presentation of data

6.6.5.8.1 Nomenclature

Table 3 gives the nomenclature used throughout 6.6.5.8 for parts of a table.

Table 3 — Nomenclature for the parts of a table

Column heading	Column heading	Spanner heading	
		Column heading	Column heading
Row heading	Tabulated data*	Tabulated data*†	Tabulated data*†
Row heading requiring runover line†			
Row heading subdivision			
Row heading subdivision with runover line†			

* The intersection of a row and a column is a cell.

† A runover line in a table shall be indented one “em” space if the rows are not otherwise clearly distinguishable from one another, e.g., by the spacing between them, numbering, or ruled lines.

6.6.5.8.2 Indentation and centering of body information

Row headings shall be flush left. Row heading subdivisions shall be indented (typically 2 “em” spaces) as exemplified in Table 3 or placed in separate cells as exemplified in Table 1.

Tabulated data within a column may be centered, flush left, flush right, or aligned on the decimal point, whichever is best for ease of reading. Columns of similar information should be handled consistently throughout the table.

6.6.5.8.3 Dimensions

When tables with dimensions are to be part of the completed document, the formulating committee should select the appropriate order of magnitude and philosophy for rounding off those dimensions and the error to be allowed in making metric conversions (see 6.6.8.1). The completed document shall reflect these decisions.

6.6.5.8.4 Abbreviations and letter symbols

If necessary to save space, use abbreviations and letter symbols in column headings, and use them more freely in the body of the table than in the text.

6.6.5.8.5 Ruled lines

Use horizontal ruled lines to separate the column and row headings from the title and from the body of the table. Use a horizontal ruled line at the bottom of the table. Other ruled lines, both vertical and horizontal, are optional.

6.6.5 Tables (cont'd)

6.6.5.8 Format and presentation of data (cont'd)

6.6.5.8.6 Summary

The following is a typical table exemplifying the guidelines of 6.6.5.8.2 through 6.6.5.8.5:

EXAMPLE

Table 27 — Electrical characteristics at $T_A = 25\text{ }^\circ\text{C}$

Parameter	Symbol	Test conditions*	Limits		Unit
			Min	Max	
Breakdown voltages					
Collector-base	$V_{(BR)CBO}$	$I_C = 10\ \mu\text{A}$	60	-	V
Collector-emitter	$V_{(BR)CEO}$	$I_C = 10\ \text{mA}$	45	-	V
Emitter-base	$V_{(BR)EBO}$	$I_E = 10\ \mu\text{A}$	4	-	V
Saturation voltage	$V_{CE(sat)}$	$I_C = 50\ \text{mA}\dagger, I_B = 5\ \text{mA}$	-	$800\ddagger$	mV
Cutoff current	I_{CES}	$V_{CE} = 40\ \text{V}\S$	-	100	nA
Forward current transfer ratio	h_{FE}	$I_C = 10\ \text{mA}, V_{CE} = 5\ \text{V}$	100	200	-
		$I_C = 50\ \text{mA}\dagger, V_{CE} = 5\ \text{V}$	80	160	-

* Per detail specification.

† Pulse test; pulse duration $\leq 1\ \text{ms}$.

‡ Reduced limit available.

§ $T_A = 70\text{ }^\circ\text{C}$.

6.6.5.9 Informal tables

Small, simple tables, typically those that are not more than four or five lines long and have only a few narrow columns, require neither table number nor title. Such tables (see the following example) may be considered part of the text.

Category	ESD sensitivity (V)
A	20–2000
B	>2000

6.6.6 References

6.6.6.1 General

As a general rule, references to particular pieces of text shall be used instead of repetition of the original source material, since such repetition involves the risk of error or inconsistency and increases the length of the document. However, if it is considered necessary to repeat such material, its source shall be identified precisely.

References shall be made in the forms indicated in 6.6.6.2 through 6.6.6.5 and shall not be made to page numbers.

6.6.6.2 References to the standard as a whole in its own text

Generally, the form “this standard ...” should be used. However, to avoid possible confusion in the case where a standard is published in separate parts, the following forms may be used:

- “this part of EIA-999” (reference to a part only);
- “EIA-999” (reference to a whole series of parts).

Such references are understood to include any errata and/or future amendments to the standard.

6.6.6.3 References to elements of text

6.6.6.3.1 Elements of text shall be referred to in forms such as

- “in accordance with clause 3”,
- “according to 3. 1”,
- “as specified in 3. 1 b)”,
- “details as given in 3.1.1”,
- “see annex B”,
- “the requirements given in B.2”,
- “see the note in Table 2”, and
- “see example 2 in 6 6.3”.

It is unnecessary to use the term “subclause” in references.

6.6.6.3.2 If there is a need to refer to an item in a list whose items are not numbered or lettered in *another* standard, the following formulation shall be used:

“as specified in EIA-999:1996, 3.1, second list item”.

6.6.6 References (cont'd)

6.6.6.4 References to tables and figures

Every table and figure included in the standard shall normally be referred to in the text. Tables and figures shall be referred to in forms such as

- “given in Table 2”,
- “(see Table B.2)”,
- “shown in Figure A.6”, and
- “(see Figure 3)”.

6.6.6.5 References to other documents

6.6.6.5.1 General

References to other documents may be dated or undated. All normative references, dated and undated, shall be given in the “Normative references” clause (see 6.2.2).

6.6.6.5.2 Dated references

Except as provided for in 6.6.6.5.3, normative references shall be dated (a) by giving the date of publication, if published, or (b), in the case of final drafts, by using a dash to indicate that the document has not yet been published. References to specific divisions or subdivisions, tables, and figures of another document shall always be dated. Subsequent amendments to, or revisions of, dated references will need to be incorporated by amendment of the standard referring to them.

NOTE In this context a part is regarded as a separate standard.

Use the following forms:

- “... carry out the tests given in EIA-999-1:July 1988 ... ”;
- “... in accordance with EIA-1234: —, clause 3, ... ”;
- “... as specified in IEC 4321-4:1996, Table 1, ... ”.

See also 6.6.6.3.2.

6.6.6 References (cont'd)

6.6.6.5 References to other documents (cont'd)

6.6.6.5.3 Undated references

Undated references may be made only to a complete document or a part thereof (as defined in 5.2.1) and only in the following cases:

- a) if it is probable that all future revisions of the document referred to will remain useable for the purposes of the referring standard;
- b) for informative references.

Undated references shall be understood to include all amendments to and revisions of the quoted publication.

Use the following forms:

— “... as specified in EIA EP-20 ...”;

— “... see IEEE Std 100 ...”.

6.6.7 Representation of numbers and numerical values

6.6.7.1 IEC directives state that the *decimal sign* shall be a comma in all language versions of international standards. However, for EIA publications, the period shall be used as the decimal sign unless special circumstances exist that justify the use of the comma in a particular case. In this case, the special circumstances that justify the use of the comma and an explanation of its significance shall be included prominently within the document.

6.6.7.2 Use arabic numerals for all *values of measure*. If a value less than unity is written in decimal form, the decimal sign shall be preceded a zero.

EXAMPLE 1 0.08 inch

EXAMPLE 2 0.42 mm

6.6.7.3 Although ISO and IEC require the use of a comma as the decimal sign in international standards, they recognize that a period is more likely to be used in documents produced in English. Therefore, to minimize confusion, the use of either mark (i.e., a comma or a period) for the *separation of digits into groups of three* is deprecated worldwide. Instead, a small space should be used. In numbers of four digits, the space is usually not necessary, except for uniformity in tables.

6.6.7 Representation of numbers and numerical values (cont'd)

6.6.7.3 (cont'd)

The following tabulation illustrates conventional practices. The “international” forms are mandatory for EIA publications. See 6.6.7.1 concerning the decimal sign.

USA	Europe	International
0.17	0,17	0.17 or 0,17
3.6149	3,614 9	3.614 9 or 3,614 9
33.6	33,6	33.6 or 33,6
1,215 or 1215	1.215 or 1215	1 215 or 1215
2,356,870	2.356.870	2 356 870

6.6.7.4 A *multiplication sign* (\times), rather than a raised dot, shall be used to indicate multiplication of numbers and numerical values.

EXAMPLE 1.8×10^{-3} (not $1.8 \cdot 10^{-3}$)

6.6.7.5 In general, in *expressing numbers* of items (as opposed to numerical values of physical quantities), the numerals one to nine shall be spelled out. Numerals applicable to the same category should be treated alike throughout a paragraph; do not use figures for some and spell out others. If the largest is greater than nine, use numerals for all unless the number is a quantity that precedes a value of measure (e.g., twelve 4.5-volt batteries).

EXAMPLE 1 Carry out the test on five tubes, each 5 m long.

EXAMPLE 2 Select 8 to 12 devices for the pressure test.

To express numerical values of physical quantities, arabic numerals accompanied by the international symbol for the unit (see ANSI/IEEE Std 260.1) shall be used.

6.6.7.6 Use of the words “*billion*” and “*trillion*” is deprecated because of a high probability of misunderstanding. Billion means 10^9 in the USA but 10^{12} in Europe. Trillion means 10^{12} in the USA but 10^{18} in Europe.

6.6.8 Quantities, units, symbols, and signs

6.6.8.1 Mathematical signs and symbols

Mathematical signs and symbols shall be in accordance with ANSI/IEEE Std 260.3.

6.6.8 Quantities, units, symbols, and signs (cont'd)

6.6.8.2 Letter symbols for electrical or physical quantities

Symbols for quantities shall be chosen, wherever possible, from ANSI/IEEE Std 260.1 and ANSI/IEEE Std 280 or other appropriate EIA or ANSI standards.

In a particular document, use the same letter symbol throughout for the same physical quantity, regardless of the units employed or of the special values assigned. American National standards for letter symbols in particular fields should be used if they have been established (see annex C). Also see JEDEC JESD77, JESD99, and JESD100.

6.6.8.3 Units of measure

The units in which any values are expressed shall be indicated. The units of the International System (SI) shall be used in EIA documents (U.S. customary units may be given in parentheses).

For units, refer to ANSI/IEEE Std 260.1. Letter symbols from ANSI/IEEE Std 260.1 are included in section 4 of ANSI Y1.1 for those unit terms for which ANSI Y1.1 has established an abbreviation. SI units and metric equivalents of U.S. Customary units shall be in accordance with ANSI/IEEE Std 268.

In text, spell out units in which quantities are measured unless their length or repetition would slow reading and comprehension. Nonstandard abbreviations (e.g., amps, megs) should not be used. If the quantity is less than one, use the singular, e.g., 0.7 meter, not 0.7 meters.

When using symbols for units, always observe distinctions between uppercase and lowercase (e.g., “m” denotes milli and “M” denotes mega; “s” denotes second and “S” denotes siemens); the case (upper or lower) shall not change regardless of context. Leave a space between the numeral and its unit (e.g., 4.5 V, not 4.5V; 34.7 mm, not 34.7mm; 25 °C, not 25°C) except for angles (e.g., 20°17'48”). Do not use a space between multiple symbols that represent a single unit (e.g., use mmHg,¹⁾ not mm Hg; 25 °C, not 25° C).

When a quantity expressed as a numerical value and a unit is used as an adjective, a hyphen should be used in lieu of a space between the number and the unit name or symbol (e.g., “a 5-V breakdown voltage”). In this case, if the name of the unit is spelled out, always use the singular form (e.g., a 5-volt breakdown voltage).

6.6.9 Mathematical formulas

6.6.9.1 Types of equations

Equations shall be expressed in mathematically correct form, the variables being represented by letter symbols whose meanings are explained in connection with the equations, unless they appear in a “Symbols and abbreviated terms” clause (see 6.3.2). Descriptive terms or names of quantities shall not be arranged in the form of an equation.

Set the word “where”, which introduces the explanatory material, flush left under the equation. (Note that “where” is all lowercase, not initial capital.)

1) The pascal (Pa) is the SI unit for pressure.

6.6.9 Mathematical formulas (cont'd)

6.6.9.1 Types of equations (cont'd)

For equations between quantities (which are valid for any consistent set of units), the style shown in example 1 shall be followed.

EXAMPLE 1

$$v = d/t$$

where

- v is the velocity of a point in uniform motion;
- d is the distance traveled;
- t is the time interval.

If an equation contains numerical values, the style shown in example 2 shall be followed.

EXAMPLE 2

$$v = 3.6 \times d/t$$

where

- v is the numerical value of the velocity, expressed in kilometers per hour (km/h), of a point in uniform motion;
- d is the numerical value of the distance traveled, expressed in meters (m);
- t is the numerical value of the time interval, expressed in seconds (s).

However, the same symbol shall never be used within a standard both for a quantity and for its corresponding numerical value. For example, use of the equation in example 1 and of the equation in example 2 in the same context would imply that $1 = 3.6$, which obviously is not true.

6.6.9.2 Presentation

Insofar as possible, symbols having more than one level of subscript or superscript shall be avoided, as shall any symbols and formulas that would involve printing more than two lines of type.

EXAMPLE 1 a_{VF} (the temperature coefficient of V_F), not a_{VF}

EXAMPLE 2 In the text, a/b is preferable to $\frac{a}{b}$, and $c/(d + e)$ is preferable to $\frac{c}{d + e}$

6.6.9 Mathematical formulas (cont'd)

6.6.9.2 Presentation (cont'd)

EXAMPLE 3 In a displayed formula

$$\frac{\sin[(N+1)\varphi/2]\sin(N\varphi/2)}{\sin(\varphi/2)}$$

is preferred to

$$\frac{\sin\left[\frac{(N+1)}{2}\varphi\right]\sin\left(\frac{N}{2}\varphi\right)}{\sin\frac{\varphi}{2}}$$

A further example of the presentation of mathematical formula is given in example 4.

EXAMPLE 4

$$\frac{x(t_1)}{x(t_1+T/2)} = \frac{e^{-\delta t_1} \cos(\omega t_1 + \alpha)}{e^{-\delta(t_1+T/2)} \cos(\omega t_1 + \alpha + \pi)} = -e^{\delta T/2} \approx -1.392 15$$

where

- x is the x-coordinate;
- t_1 is the time at the first turning point;
- T is the periodic time;
- ω is the angular frequency;
- α is the initial phase;
- δ is the damping coefficient;
- π is the number 3.141 592 6...

6.6.9.3 Numbering

If it is necessary to number some or all of the formulas in a publication in order to facilitate cross-reference, arabic numbers in parentheses shall be used, as in the following example:

$$x^2 + y^2 = z^2 \tag{1}$$

The numbering shall begin with 1 and be consecutive and independent of the numbering of clauses, tables, and figures. Set the formula number (enclosed in parentheses) flush right. If a formula is two or more lines long, set the formula number flush right on the last line of the formula. Formula numbers in an annex should be prefixed by the identifying letter of the annex followed by a dot, e.g., “(B.4)”.

6.6 Common rules and elements (cont'd)

6.6.10 Dimensions and tolerances

Dimensions and tolerances shall be indicated in an unambiguous manner.

EXAMPLE 1 80 mm × 25 mm × 50 mm, not $80 \times 25 \times 50$ mm

EXAMPLE 2 $80 \mu\text{F} \pm 2 \mu\text{F}$ or $(80 \pm 2) \mu\text{F}$, not $80 \mu\text{F} \pm 2$ or $80 \pm 2 \mu\text{F}$

EXAMPLE 3 80 mm +50/−20 μm

EXAMPLE 4 5 V ± 10%

EXAMPLE 5 0 °C to 10 °C (not 0 to 10 °C)

In order to avoid misunderstanding, tolerances on percentages shall be expressed in a mathematically correct form.

EXAMPLE 6 Write “from 63% to 67%” to express a range.

EXAMPLE 7 Write “ $(65 \pm 2)\%$ ” to express a center (percentage) value with tolerance.

The forms “ $65 \pm 2\%$ ” and “ $65\% \pm 2\%$ ” shall not be used.

6.6.11 Page numbers

The cover and inside cover are unnumbered. Number other pages of preliminary elements consecutively, starting with the contents, using lowercase roman numerals at the bottom of the page.

Number the pages containing normative elements with arabic numerals, beginning with 1, in the upper right-hand corner for odd-numbered pages and in the upper left-hand corner for even-numbered pages. Use of sequential page numbers throughout this portion of the document is preferred. However, page numbering by section (e.g., labeling the first page of section 3 as 3-1) is permitted.

If the pages containing normative elements are numbered consecutively throughout the document, continue this number series for the supplementary elements. If the text portion is numbered by section, the annexes shall use arabic numerals, starting with 1 and prefixed by the identifying letter of the annex and a dash (e.g., A-1, B-1, C-1), and the index shall use arabic numerals starting with 1 and preceded by the word “Index” and a dash (e.g., Index-1, Index-2, Index-3).

6.6.12 Page headings

Page headings shall include the document number and (except for foreword and contents) the page number, as done in this manual. The headings should start 1 inch (25 mm) down from the top of the page and be flush right for odd-numbered pages and flush left for even-numbered pages. Leave two lines between the heading and the page content.

6.6 Common rules and elements (cont'd)

6.6.13 Special needs

If a committee has a valid reason for diverging from the organization and numbering system just described, the committee editor should consult the EIA Technology Strategy and Standards Department Publications Office before the proposed document is submitted.

7 Presentation

7.1 Page dimensions

Documents should be presented on 8.5-inch by 11-inch paper (U.S. letter) with minimum top and bottom margins (i.e., nonprinted areas) of 0.5 inch and minimum left-hand and right-hand margins of 1.0 inch. If documents are presented on 210-mm by 297-mm tall paper (A4 size) use minimum top and bottom margins of 21.5 mm and minimum left-hand and right-hand margins of 22.5 mm. In either case, this will result in a maximum print area of 6.5 inches by 10 inches (165 mm by 254 mm). See Figure 1.

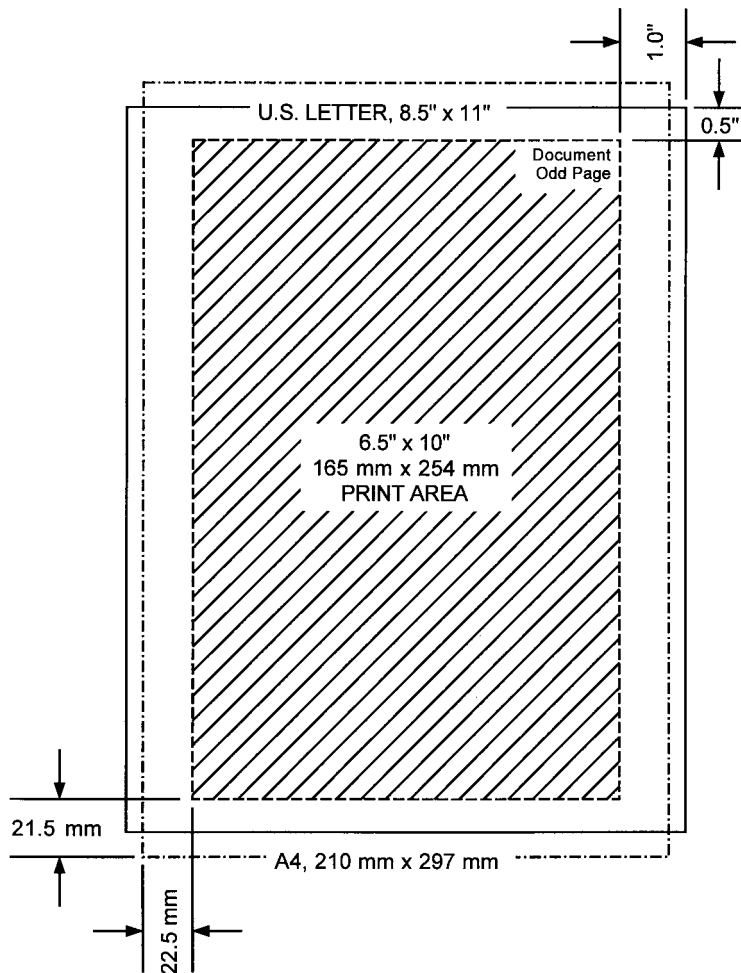

Figure 1 — Page dimensions (right-hand page)

7.2 Layout

7.2.1 Text

Documents shall be presented with the text in portrait format (reading across the narrow page dimension). The numbers and text of clauses and subclauses shall be aligned on the left-hand margin of the page. For an example layout of a manuscript, see annex M.

7.2.2 Tables and figures

Tables and figures should be presented on a single portrait-format page, if possible. Wide figures and tables may be rotated counter-clockwise 90° and presented in landscape format (reading from bottom to top of the page). Longer tables are set on multiple pages. See Figure 2.

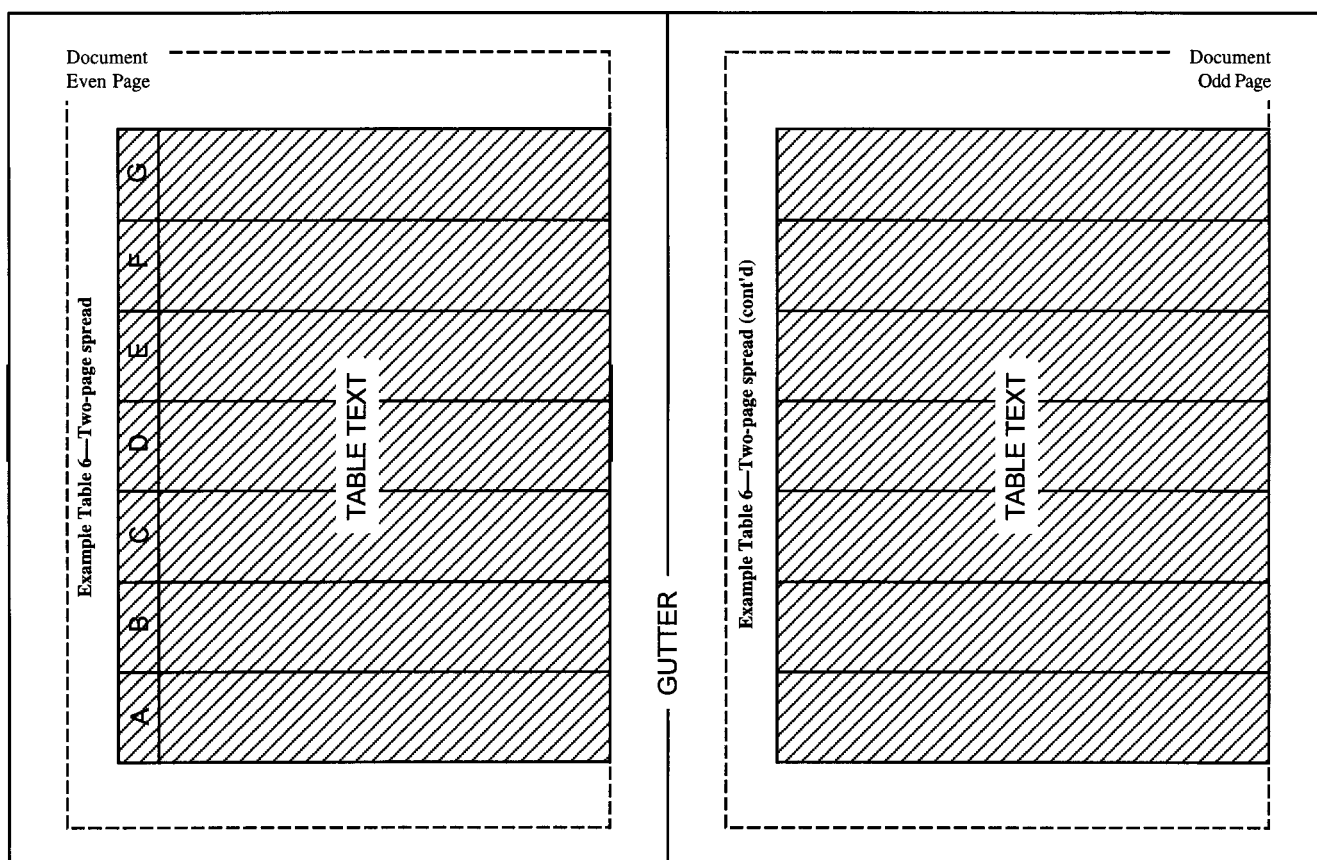

Figure 2 — Two-page spread in landscape format

Tables and figures that are too wide for presentation in landscape format may be set across facing pages. In the case of tables, all text shall remain within the margins specified in 7.1 but rules may be extended through the gutter on each page. See Figure 3.

7.2 Layout (cont'd)

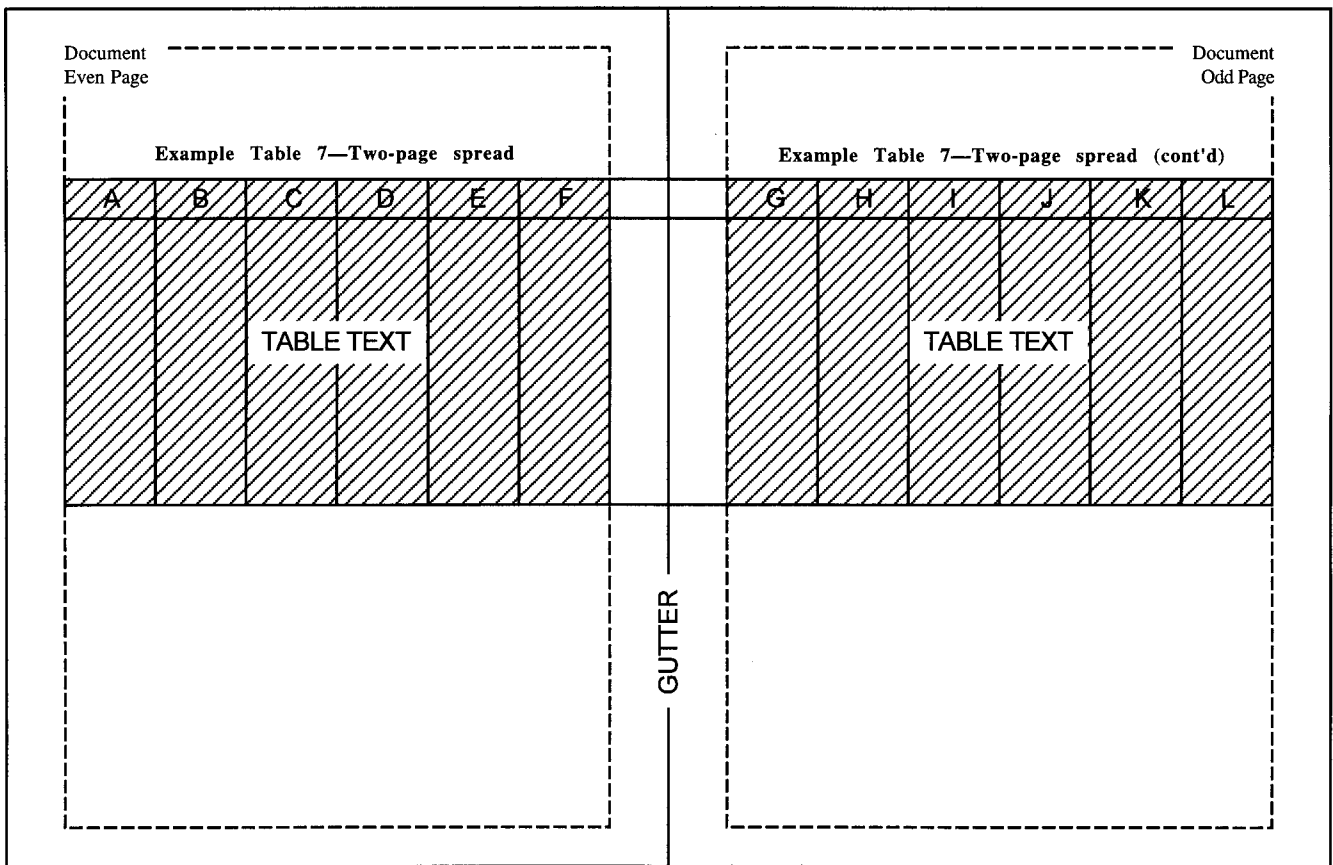

Figure 3 — Two-page spread in portrait format

7.3 Typography

7.3.1 *Document titles and section titles (as defined and illustrated in 5.2.2)* may be set in type up to 4 points larger than the text font. Use bold-face sans-serif fonts, Arial (preferred) or Helvetica, and the Symbol font if required.

NOTE Typography used on covers of publications is not specified in this manual.

7.3.2 *Text* shall be set in 10- to 15-point serif type using Times or Times New Roman, and the Symbol font if required, and flush left.

7.3.3 *Subscripts and superscripts* will generally be legible when 11-point or larger type is used for the text. For 10-point text, if software reduces their size, the subscripts and superscripts should be enlarged for legibility.

7.3.4 *Notes, footnotes, and tables* may be set 1 point or 2 points smaller than the text but not smaller than 9 points. See also 6.5.1.

7.3 Typography (cont'd)

7.3.5 Text in *drawings and graphs* that is intended to be readable (rather than for purposes of illustration only) shall be set so that when published, it shall be in 10- to 15-point type using Arial, Helvetica, Times, or Times New Roman fonts, and the Symbol font if required. Text in 16-point or larger type shall use Arial (preferred) or Helvetica, and the Symbol font, if required.

7.3.6 *Special fonts*, such as mathematical symbols or chemical symbols, not included in the fonts specified above, must be electronically included with the draft to the EIA Technology Strategy and Standards Department Publications Office.

Annex A (informative) Differences between EP-7-C and ISO/IEC Directives, Part 3, 1997

This table briefly points out substantive differences between EP-7-C and ISO/IEC Directives, Part 3, 1997. References changed from ISO and IEC standards to ANSI standards believed to be equivalent are not included. Likewise, sections that refer to EIA policies and procedures are not included here.

EP-7-C	ISO/IEC	Difference
	4.4	IEC's <i>Equivalence of official language versions</i> does not apply.
5.1.3	5.1.3	IEC Table 2 does not include <i>Notice and Related EIA documents</i> .
5.2.2		IEC no longer recognizes the <i>section</i> .
5.2.5	5.2.4	IEC does not permit clauses (or subclauses) that contain one or more subclauses to include text that precedes those subclauses. EP-7-C merely discourages this practice.
6.1.3	6.1.2	Per IEC, <i>Table of contents</i> is optional. EIA requires this for documents of greater than 10 pages. IEC requires the table of contents, if provided, to be generated automatically in electronic documents.
6.3.3	6.3.3	IEC does not list <i>d) precautions to be observed, e) allowable variations and quality or reliability information, and f) other technical requirements</i> .
6.3.8		IEC does not include <i>Application notes</i> .
6.4.3	6.4.3	IEC requires that <i>indexes</i> , if provided, be prepared by automatic means.
6.5.2	6.5.2	IEC requires that footnotes to the text be numbered sequentially throughout a document.
6.6.2.1	6.6.2	IEC recommends <i>The Shorter Oxford Dictionary</i> and <i>The Concise Oxford Dictionary</i> .
6.6.2.3	6.6.2	IEC uses periods in abbreviations such as “d.c.” whereas EIA does not.
6.6.2.4		IEC does not include <i>Compound words and hyphenation</i> .
6.6.2.5		IEC does not include <i>Widows and orphans</i> .
6.6.2.6		IEC does not include <i>Capitalization</i> .
6.6.6.7		IEC does not include “ <i>That</i> ” and “ <i>which</i> ”.
6.6.2.8		IEC does not include <i>Frequently misused words and phrases</i> .
6.6.3.2		IEC does not include <i>Patented items or processes</i> .
6.6.3.3		IEC does not include <i>Copyrighted material</i> .
6.6.4.3	6.6.4.3	IEC requires that figures be numbered sequentially throughout a document.
6.6.4.10		IEC does not include <i>Informal figures</i> .
6.6.5.2	6.6.5.2	IEC requires that tables be numbered sequentially throughout a document.
6.6.5.7	6.6.5.7	IEC requires that footnotes to tables be referred to by letters, not symbols.
6.6.5.8		IEC does not include <i>Format and presentation of data</i> .
6.6.5.9		IEC does not include <i>Informal tables</i> .
6.6.7.1	6.6.7.1	IEC requires the comma as the decimal sign. EIA generally requires the period.
6.6.7.6		IEC does not cover use of <i>billion or trillion</i> .
6.6.11		IEC does not include <i>Page numbers</i> .
6.6.12		IEC does not include <i>Page headings</i> .
6.6.13		IEC does not include <i>Special needs</i> .
7		IEC does not have rules for page size, margins, and typography as these are considered to be governed by the house style of the publishing organizations.
Annex G	Annex C	IEC has adopted formatting rules for <i>terms and definitions</i> that harmonize with ISO but differ considerably from US practice. The EIA rules have remained basically unchanged from former IEC and EIA practice. Specifically, IEC has the term, synonyms, and the definition each start on a separate line; definitions start with no leading article and a lowercase letter and end without a period.

Annex B (informative) Differences between EP-7-C and EP-7-B

This table briefly points out substantive differences between this standard, EP-7-C, and its predecessor, EP-7-B. Only changes that require different procedures are included.

EP-7-C	EP-7-B	Difference
5.2.6	4.1.3	The punctuation of lists is changed.
5.2.7	3.3.6	Annexes are to be placed in the order in which they are first cited in the text. Previously, all normative annexes were presented ahead of all informative annexes.
5.2.8	4.5.1	A bibliography is now a distinct element as opposed to an informative annex.
6.1.4	2.2.3	Lists of tables and figures are no longer optional.
6.2.2	2.3.3	Wording of introductory text for normative references is changed to differentiate dated and undated references. See also 6.6.6.5
6.5.1	3.4	The format for multiple notes integrated in the text has been changed. Rules relating to examples have been added.
6.6.4.8	2.5.4	Notes to figures may no longer contain requirements, but see 6.6.4.9.
6.6.4.9	2.5.2	Footnotes to figures may contain requirements.
6.6.5.6	2.5.4	Notes to tables may no longer contain requirements, but see 6.6.5.7.
6.6.5.7	2.5.2	Footnotes to tables may contain requirements.
6.6.6.5	4.4.4	The rules relating to references have been revised to distinguish between dated and undated references.
6.6.9	4.6	The text concerning mathematical formulas has been revised in conformity with ISO/IEC <i>Directives, Part 3</i> , 1997 and ISO 31-0.
7	3.4	Material has been added regarding page size, margins, figure rotation, and typography.

Annex C (informative) Basic standards of EIA, ANSI, and IEEE

C.1 Introduction

This annex gives a nonexhaustive list of the most generally applicable basic standards (see 4.3). For specific subjects, the provisions of other, less generally applicable, standards will be applicable.

The reference works for language are also given (see 6.6.2).

C.2 Reference works for language

Merriam-Webster's Collegiate Dictionary, Tenth Edition.

Webster's Third New International Dictionary, Unabridged.

C.3 Standardized terminology

ANSI/IEEE Std 100, *IEEE Standard Dictionary of Electrical and Electronic Terms.*

JEDEC JEP120, *Index of Terms Defined in JEDEC Publications.*

JEDEC JESD77, *Terms, Definitions, and Letter Symbols for Discrete Semiconductor and Optoelectronic Devices.*

JEDEC JESD99, *Terms, Definitions, and Letter Symbols for Microelectronic Devices.*

JEDEC JESD100, *Terms, Definitions, and Letter Symbols for Microcomputers and Memory Integrated Circuits.*

C.4 Mathematical signs and symbols

ANSI/IEEE Std 260.3, *Mathematical Signs and Symbols for Use in Physical Science and Technology.*

C.5 Quantities, units, and their symbols

ANSI X3.50, *Representation for U.S. Customary, SI, and Other Units to be Used in Systems with Limited Character Sets.*

ANSI/IEEE Std 260.1, *Letter Symbols for Units of Measurement (SI Units, Customary Inch-Pound Units, and Certain Other Units).*

ANSI/IEEE Std 280, *Letter Symbols for Quantities Used in Electrical Science and Electrical Engineering.*

ANSI/IEEE/ASTM SI 10, *Standard for Use of the International System of Units (SI): The Modern Metric System.*

JEDEC JEP104, *Reference Guide to Letter Symbols for Semiconductor Devices.*

Annex C (informative) Basic standards of EIA, ANSI, and IEEE (cont'd)

C.6 Abbreviated terms

ANSI/ASME Y1.1, *Abbreviations for Use on Drawings and in Text.*

C.7 Technical drawings

ANSI/ASME Y1.1, *Abbreviations for Use on Drawings and in Text.*

ANSI Y14.5M, *Dimensioning and Tolerancing.*

ANSI/ASME Y14.1M, *Metric Drawing Sheet Size and Format.*

ANSI/ASME Y14.2M, *Line Conventions and Lettering.*

ANSI/ASME Y14.3M, *Multiview and Sectional View Drawings.*

ANSI/ASME Y14.4M, *Pictorial Drawing.*

ANSI/ASME Y14.24M, *Types and Applications of Engineering Drawings.*

ANSI/IEEE Std 200, *Reference Designations for Electrical and Electronics Parts and Equipment.*

C.8 Graphical symbols and diagrams

ANSI Y14.15, *Electrical and Electronics Diagrams.*

ANSI/IEEE Std 91, *Graphic Symbols for Logic Functions.*

ANSI/IEEE Std 315, *Graphic Symbols for Electrical and Electronics Diagrams.*

ANSI/IEEE Std 991, *Logic Circuit Diagrams.*

Annex D (normative) Preparation of the final manuscript by the formulating committee

D.1 Responsibility of formulating committees and working groups

Committees and working groups are responsible for submitting to EIA staff standards and publications proposals that are complete and accurate, both technically and editorially. These documents must meet the requirements of this manual for content, arrangement, and legibility and must conform to EIA special policies. Style is also important, especially with respect to the requirements for abbreviations (see 6.6.2.2), unit and letter symbols (see 6.6.8), and the numbering system (see 5.2.3, 5.2.4, 6.6.5.2, and 6.6.4.3).

Because a proposal often undergoes several revisions in the development stage and passes through many hands before the final draft is approved by the formulating committee, EIA recommends that each committee appoint an editor. The editor should review the final draft before it is submitted to the EIA staff to ensure that it is a complete and accurate document as approved by the committee; that it meets the requirements of this style manual; and that it is ready for publication as a proposal. Page proofs of the final prepublication draft will be sent to the editor for a final preprinting check. If no editor is designated, the chair of the formulating committee should exercise these functions.

D.2 Document submission for publication

D.2.1 Choice of formats

The document shall be submitted to the EIA Technology Strategy and Standards Department Publications Office in a form suitable for publication. Either electronic or hard-copy format may be used.

D.2.2 Electronic format

Today the majority of document elements are generated using computer technology. The systems used range from basic word processors to advanced technical illustration and page-layout packages. Much of the publication process at EIA is completed using an electronic publishing system; therefore, it is requested that the manuscript elements be submitted in electronic form. This will greatly improve the efficiency, accuracy, and speed of the publication process.

The EIA Technology Strategy and Standards Department Publications Office can accept a wide variety of file formats originating from a number of different computer platforms. Preferred software is MS Word (.doc), MS Excel (.xls), MS Powerpoint (.ppt), and other software as pre-approved by the responsible sector staff. The committee editor who chooses to provide an electronic manuscript should consult with the Publications Office as soon as possible in the writing process to determine the most suitable document preparation and file format. The earlier in the process this consultation takes place, the more efficient the publication process will be.

To further aid the editorial and production process, a printout of the electronic manuscript also should be provided.

Annex D (normative) Preparation of the final manuscript by the formulating committee (cont'd)

D.2.3 Hard-copy format

If used, submission in hard-copy format shall be on 8 1/2-inch by 11-inch paper, single spaced with margins of at least 1 inch (25 mm) on all four sides of each page. All copy shall be clean and clear.

D.3 Artwork

To speed publication, the formulating committee should provide line drawings, photos, or photo negatives suitable for good quality reproduction. To avoid loss or mishandling, identify artwork properly and send it directly to the EIA Publications Office. The artwork shall be returned to the originator if it is so annotated.

D.4 Mathematical expressions

Avoid freehand drawing of Greek symbols or other mathematical expressions if printed versions are available. Care must be exercised if hand drawing is necessary.

Annex E (normative) Functions of the EIA Technology Strategy and Standards Department Publications Office

E.1 General

Following public comment and comment resolution, the EIA Technology Strategy and Standards Department Publications Office converts the standards proposal into a printed standard. This process includes editing in accordance with this manual, accepted usage, and the reference documents listed in annex C; text processing and makeup; proofchecking; and arranging for printing.

The Publications Office makes editorial changes to the document that result from the public review and comment period and are agreed to by the formulating committee's chair and editor. The decision on whether a recommended change is editorial or substantive shall be made by the EIA Technology Strategy and Standards Department vice president or staff in consultation with the formulating committee chair. The acceptance of a substantive change through this process shall result in a revision of the proposed document and another public review.

E.2 Editing

An EIA editor shall carefully review the final manuscript of the document for sense, clarity of expression, and organization. Where necessary, the editor shall correct

- spelling, punctuation, hyphenation, and grammar;
- abbreviations, acronyms, letter and unit symbols, and drafting practices that do not conform to the requirements described in this manual;
- numbering system and any other stylistic requirements described in this manual;
- incomplete or erroneous references to EIA or American National standards.

If changes beyond these relatively simple and straightforward ones seem necessary, the editor shall consult with the chair or editor of the formulating committee.

E.3 Final approval

The EIA's Technology Strategy and Standards Department Publications Office shall proof the page copy and submit a copy to the chair or the editor of the formulating committee for review and approval prior to printing and releasing the document.

EIA standards require approval by the chair of the Engineering Department Executive Committee (EDEC).

Annex F (informative) Example of numbering of divisions and subdivisions

Example of numbering of divisions and subdivisions.

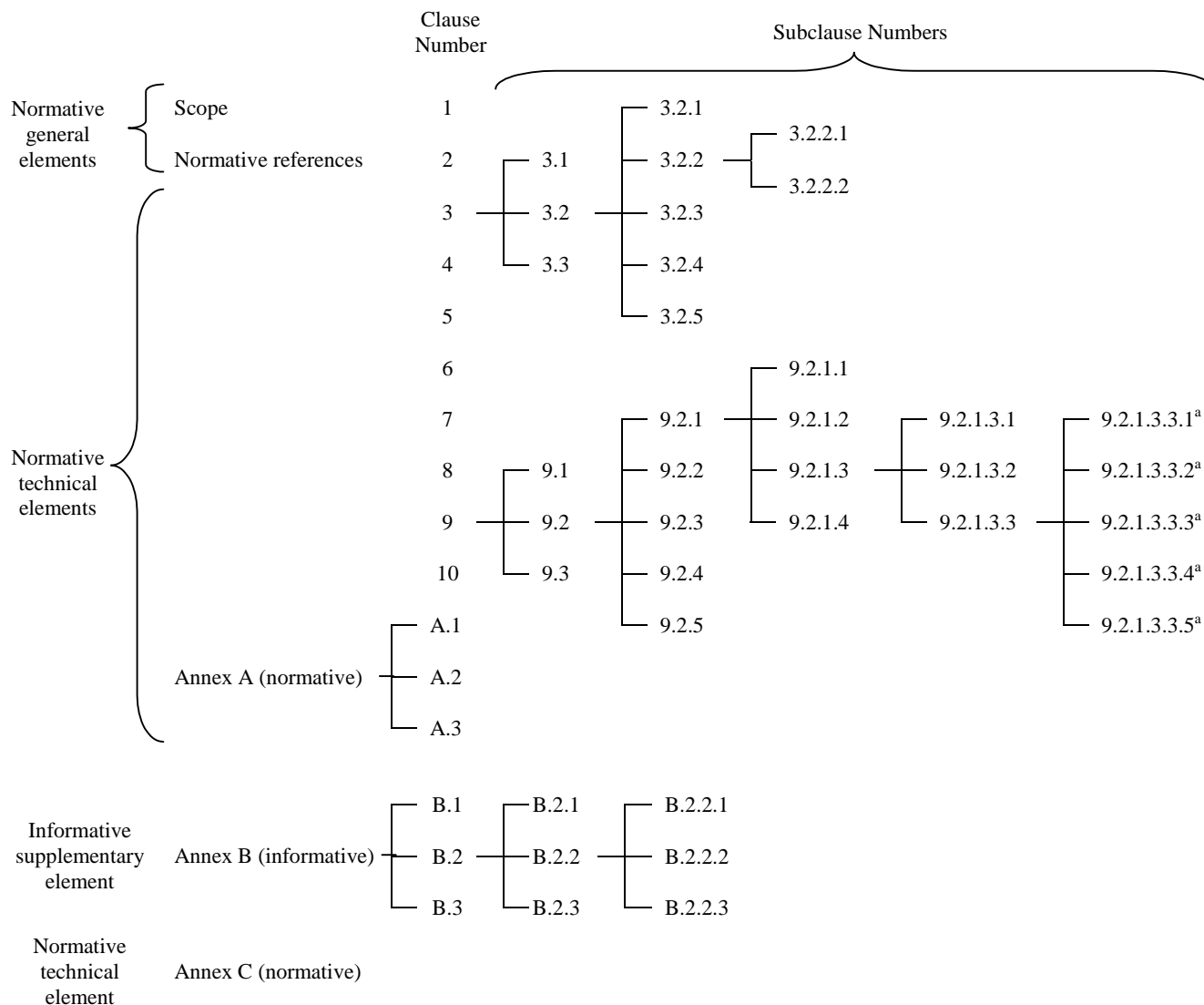

a) Maximum of six levels, i.e., a clause and five levels of subclauses.

Annex G (normative) Drafting and presentation of terms and definitions

G.1 General principles

G.1.1 Types of standard

Terminology may take the form of an independent terminology standard (e.g., “Terms, Definitions and Letter Symbols for...”) or be included in a “Terms and definitions” clause in a standard that also deals with other aspects.

G.1.2 Choice of concepts to be defined

Any term that is not self-explanatory or commonly known and that can be differently interpreted in different contexts shall be clarified by defining the relevant concept.

Common dictionary or current technical terms shall be included only if they are used with a specific meaning in the relevant context.

Trade names (brand names) and archaic and colloquial terms shall be avoided.

Deprecated terms may be included but their nature shall be indicated by “(deprecated: . . .)”. The preferred term shall be shown.

In an independent terminology standard, the concepts defined shall be restricted to the field corresponding to the title and scope of the standard. In other standards, only such concepts shall be defined as are used in those standards, apart from any additional concepts and their terms that may be deemed necessary for the understanding of these definitions.

G.1.3 Avoidance of duplications and contradictions

Before a term and a definition are established for a concept, it should be ascertained that no other term and definition for that concept exist in another standard. Consider the terms and definitions found in ANSI/IEEE Std 100 and in EIA and JEDEC standards covering related technical subjects. JEDEC Publication 120 is an index of most terms defined in JEDEC standards and publications.

If the concept is used in several standards, it is preferable to define it in the most general of those standard or in an independent terminology standard. The other standards should then refer to that standard without repeating the definition of the concept.

If the repetition of a definition is necessary, an informative reference shall be made to the standard from which it is reproduced.

EXAMPLE 1 block: A continuous range of memory addresses. (Ref. IEC 748-2)

If it is necessary to expand or restrict a definition from another standard, that fact shall be noted. In example 2, the underlined words have been added.

Annex G (normative) Drafting and presentation of terms and definitions (cont'd)

G.1.3 Avoidance of duplications and contradictions (cont'd)

EXAMPLE 2 random-access memory (RAM): A memory that permits access to any of its address locations in any desired sequence with similar access time to each location. (Adapted from IEC 748-2.)

If a term is defined in one standard, the introduction in another standard of a different term (synonym) for the defined concept is strongly deprecated.

G.1.4 Drafting of definitions

G.1.4.1 A definition shall contain all necessary and sufficient elements to enable the considered concept to be well understood and its boundaries to be determined. Any supplemental information or clarification shall be added only in the form of notes or examples.

G.1.4.2 A definition shall be adequate for its intended purpose. It shall be theoretically correct with the precision needed in the relevant context.

G.1.4.3 The preferred structure of a definition is: a basic part stating the class to which the concept belongs and another part enumerating the characteristics that distinguish the concept from other members of the class. The narrowest well-defined or well-known class shall be chosen.

EXAMPLE hybrid computer: A computer using both analog representations and discrete representations of data.

G.1.4.4 All terms used in a definition shall be unambiguous or shall be separately defined.

G.1.4.5 Circular definitions; e.g., definitions in which one concept is defined by a second concept and the second by the first, shall be avoided.

G.1.4.6 A drawing may be used to clarify the content of a definition, but the text of the definition shall be complete in itself without the drawing.

G.1.4.7 A definition shall not take the form of, or contain, a requirement.

G.1.4.8 A definition given without an indication of its applicability may be taken as representing the general meaning of the term. Special meanings in particular contexts shall be indicated by a suitable qualification or complementary expression (see G.3.4).

EXAMPLE

index (of a file or of a document): A list of the contents of a file or of a document, together with keys or references for locating the contents.

index (of a measuring instrument): A fixed or movable part of an indicating device (pointer, luminous spot, liquid surface, recording pen, point, etc.), whose position with reference to the scale marks enables the results of the measurement to be determined.

Annex G (normative) Drafting and presentation of terms and definitions (cont'd)

G.1.4.9 Terms generally should be presented in their basic grammatical form, i.e., nouns in the singular, verbs in the infinitive.

G.1.4.10 Each definition shall have the same grammatical form as the term; to define a verb, a verbal phrase shall be used; to define a singular noun, the singular shall be used.

G.1.4.11 A derived quantity shall be defined only by means of other quantities. No units shall be used in the definition of a quantity.

G.2 Arrangement of terms

Terms should normally be arranged in alphabetical order without subsection numbers. If the definition section is short, the terms and definitions may be arranged tutorially rather than alphabetically. Lengthy groupings of definitions shall be organized into subsections and numbered in accordance with the numbering system in this manual (see 5.2.3 and 5.2.4).

G.3 Presentation

G.3.1 Rules

The following rules apply to the presentation of both independent terminology standards and the “Terms and definitions” clause of other standards.

G.3.2 Layout

Each term defined shall be placed at the beginning of the first line in bold type, after its reference number (if any) starting with a lowercase letter (unless the first word is a proper name, e.g., Darlington) and shall be followed by a colon (:) unless the definition starts on a new line. The definition shall have the form of a dictionary definition starting with an uppercase letter, without repeating the term or inserting any intervening words.

EXAMPLE **radiation hardening:** Increasing the ability of a device to survive one or more types of radiation.

G.3.3 Synonyms

Synonyms shall be separated by a semicolon (;).

EXAMPLE **registration mark; alignment mark; fiducial mark:** A mark on a wafer or substrate that is used for aligning successive processing masks.

Annex G (normative) Drafting and presentation of terms and definitions (cont'd)

G.3.4 Multiple meanings

If a term is used to represent several concepts, all meanings shall be qualified (see G.1.4.8). If this is not possible, the different meanings may be distinguished by adding arabic numerals so that separate entries are formed. All entries after the first entry should begin at the left margin as shown in the following example.

EXAMPLE

substrate (of a semiconductor device): (1) The part of the original material that remains essentially unchanged when the device elements are formed upon or within the original material.
(2) The original semiconductor material being processed.

NOTE The intended meaning will usually be clear from the context in which the term is used. If necessary, distinction can be made between the “original substrate” and the “remaining substrate”.

G.3.5 Parentheses and brackets

G.3.5.1 Parentheses () enclosing a part of a term indicate that the part of the term placed between them may be omitted if, in the context in which the term is used, no confusion is likely.

EXAMPLE **Darlington (transistor)**

The parentheses indicate that the term “Darlington” can be used alone as having the same meaning as “Darlington transistor”.

G.3.5.2 Square brackets [] enclosing a part of a term and possibly part(s) of its definition indicate that the words placed between them may replace all or some of the preceding words. Selection of the bracketed form of the term requires the selection of the bracketed form of the definition. This convention should be used only when it is necessary to economize on space or to show at first sight the construction of terms having parallel definitions.

EXAMPLE **0[1]-state:** The logic state represented by the binary number zero [one] and usually standing for an inactive [active] or false [true] logic condition.”

Annex H (normative) Drafting of the title of a document

H.1 Elements of the title (See also 6.1.1.)

H.1.1 The introductory element

The introductory element is necessary if, without it, the subject indicated in the main element is not well defined.

EXAMPLE 1

Correct: *Semiconductor devices — Signal diodes — Measurement of reverse recovery time*

Incorrect: *Signal diodes — Measurement of reverse recovery time*

The introductory element shall be omitted if the main element of the title (together with the complementary element, where present) unequivocally covers the subject matter treated in the publication.

EXAMPLE 2

Correct: *Memory integrated circuits — Terms, definitions, and symbols*

Incorrect: *Semiconductor devices — Memory integrated circuits — Terms, definitions, and symbols*

H.1.2 The main element

The main element shall always be included.

H.1.3 The complementary element

The complementary element is necessary if the publication covers only one or a few aspects of the subject indicated in the main element, or if it is necessary to distinguish it from another publication.

In the case of a standard published as a series of parts, the complementary element serves to distinguish and identify the parts (the introductory element, if present, and the main element remaining the same for each part).

EXAMPLE 1

JESD12-1 *Semicustom integrated circuits — Gate arrays — Part 1: Terms and definitions*

JESD12-5 *Semicustom integrated circuits — Gate arrays — Part 5: Design for testability guidelines*

If the publication covers several (but not all) aspects of the subject indicated in the main element, the aspects covered shall be referred to by a general term such as “specification” or “mechanical requirements and test methods” rather than be enumerated one by one.

Annex H (normative) Drafting of the title of a document (cont'd)

H.1.3 The complementary element (cont'd)

The complementary element shall be omitted if the publication both

- covers all essential aspects of the subject indicated in the main element, and
- is (and is intended to remain) the only publication relating to this subject.

EXAMPLE 2

Correct: *Transcapulators*

Incorrect: *Transcapulators — Terminology, symbols, material, dimensions, electrical properties, mechanical properties, rated values, test methods, applications, and packaging.*

H.2 Presentation of the elements

On covers, the elements of the titles shall be arranged with each element starting on a new line.

EXAMPLE

Semicustom Integrated Circuits

Gate Arrays

Part 1: Terms and Definitions

When the title is cited in text, the elements shall be separated by dashes as in the examples of H.1.1 and H.1.3.

H.3 Avoidance of unintentional limitation of the scope

The title shall not contain details that might imply an unintended limitation of the scope of the publication. However, if the publication pertains only to a specific type of product, this fact shall be reflected in the title.

EXAMPLE *Integrated circuits — Description of 54/74ACXXXXX advanced high-speed CMOS devices*

H.4 Wording

Uniformity shall be maintained in the terminology used in the titles of publications for indicating the same concept.

For publications dealing with terminology, if appropriate, one of the following expressions shall be used: “Terms and definitions” or “Terms, definitions, and symbols”.

Annex H (normative) Drafting of the title of a document (cont'd)

H.4 Wording (cont'd)

For publications dealing with test methods, whenever possible one of the following expressions shall be used: “Test method” or “Determination of ...”. Expressions such as “Method of testing”, “Method for the determination of ...”, or “Test code for the measurement of ...” shall be avoided.

In the title, no indication is needed to designate the nature of the document as a standard, publication, etc. For standards in particular, the words “guidelines”, “recommendations”, and “suggestions” should not be used in the title.

Annex J (normative) Verbal forms

NOTE Only singular forms are shown.

The verbal forms shown in Table J.1 shall be used to indicate requirements to be followed in order to conform to the standard and from which no deviation is permitted.

Table J.1 — Requirement

Verbal form	Equivalent expressions (see 6.6.1)
shall	is to is required [necessary] to it is required [necessary] that has to
shall not	is not allowed [permitted] [acceptable] [permissible] is forbidden to is not to
<p>Do not use “must” as an alternative for “shall”. (This will avoid any confusion between the requirements of a standard and external statutory regulations.) “Must” is sometimes used to indicate that the stated action is essential to successful achievement of a purpose.</p> <p>Do not use “may not” instead of “shall not” to express a prohibition.</p> <p>To express a direct instruction, for example referring to steps to be taken in a test method, use the imperative mood.</p> <p>EXAMPLE “Switch on the recorder.”</p>	

The verbal forms shown in Table J.2 shall be used to indicate that among several possibilities one is recommended as particularly suitable, without mentioning or excluding others; or that a certain course of action is preferred but not necessarily required; or that (in the negative form) a certain possibility or course of action is deprecated but not prohibited.

Table J.2 — Recommendation

Verbal form	Equivalent expressions (see 6.6.1)
should	it is recommended that ought to
should not	it is recommended that ... not it is not recommended that ought not to

Annex J (normative) Verbal forms (cont'd)

The verbal forms shown in Table J.3 shall be used to indicate a course of action permissible within the limits of the standard.

Table J.3 — Permission

Verbal form	Equivalent expressions (see 6.6.1)
may	is permitted is allowed is permissible
need not	is not required [necessary] no ... is required
Do not use “possible” or “impossible” in this context.	
Do not use “can” instead of “may” in this context.	
NOTE “May” signifies permission expressed by the standard, whereas “can” refers to the ability of a user of the standard or to a possibility.	

The verbal forms shown in Table J.4 shall be used for statements of possibility and capability, whether material, physical, or causal.

Table J.4 — Possibility and capability

Verbal form	Equivalent expressions (see 6.6.1)
can	is able to is in a position to there is a possibility of is possible
cannot	is unable to is not in a position to there is no possibility of is impossible
NOTE See note to Table J.3.	

The verbal forms shown in Table J.5 shall be used for statements of expectation or commitment.

Table J.5 — Expectation

Verbal form	Equivalent expressions (see 6.6.1)
will	is going to is expected to is intended to
will not	is not going to is not expected to is expected not to is not intended to

Annex K (informative) Spelling and proper wording

K.1 Spelling

The following list includes words frequently misspelled in technical publications.

accommodate	gray (color, US)	questionnaire
acknowledgment	grey (color, British)	
affect (verb), to influence		receive
algorithm	homogeneous	recurred
aperture	hydrofluoric	recurrence
asymmetrical	hysteresis	recurring
asymptote		referred
auxiliary	impedance	regardless
	inadvertent	reproducible
boundary	incompatible	role
	independent	
canceled	its (possessive)	separate
category	it's (it is)	separation
commitment		specimen
comparison	judgment	supersede
compatible		susceptible
complement (complete)	liaison	
compliment (praise)		their (possessive)
concomitant	miniature	they're (they are)
consensus		transferred
consistent	noticeable	
contaminant (noun)		vacuum
contaminate (verb)	occurred	vertical
cont'd <i>or</i> cont. (not con't)	occurrence	volume
	occurring	
desiccator	optimize	
deterrent	oriented	
development		
discrete	pedestal	
dissipate	peripheral	
	personnel	
effect (noun, result)	phosphorus	
(verb, to bring about)	precede	
excellent	predominant (adjective)	
existence	predominate (verb)	
	preferred	
flexible	principal (adjective, foremost)	
fluorescent	principle (noun, rule)	
fusible	privilege	
focused	proceed	
	procedure	
	producible	
	proprietary	

Annex K (informative) Spelling and proper wording (cont'd)

K.2 Proper wording

The following list includes phrases and words commonly misused in technical publications.

Correct

an LSI device
an NMOS transistor

a criterion
a phenomenon
the dice are

e.g. — meaning “for example” (always followed by a comma)
i.e. — meaning “that is” (always followed by a comma)

imply — to indicate indirectly (the speaker implies)
infer — to derive by reasoning or evidence,
to surmise (the listener infers)

percent (always with a numeral)
percentage (without a numeral)

the principal reasons
the governing principle

an alternative method
an effect
the switch is actuated
ensure — meaning “to make certain”
regardless

worst case
optimum
unique

Incorrect

a LSI device
a NMOS transistor

a criteria
a phenomena
the die are

i.e.
e.g.

I imply from what you said ...
This document infers that ...

per cent
a large percent

the principle reasons
the governing principal

an alternate method
an affect
the switch is activated
insure
irregardless

worse case
more optimum
more unique

NOTE Either “a” or “an” may be used with certain acronyms that may be pronounced either as words or as separate letters, one having a vowel sound and the other not, e.g., MOS (*a* “moss” or *an* “em-oh-ess”) or NASA (*a* “nassa” specification or *an* “en-ay-ess-ay” specification).

Annex L (informative) Symbols and abbreviations

The following list includes selected technical abbreviations.

Unit or term	Symbol or abbreviation
alternating current	ac or AC*
American wire gauge	AWG
ampere	A
ampere-hour	A·h
amplitude modulation	AM
angstrom†	Å
average	avg, Avg, or AVG*
binary coded decimal	BCD
British thermal unit	Btu
candela	cd
candela per square meter	cd/m ²
coulomb	C
decibel	dB
decibel referred to 1 mW	dBm
degree Celsius	°C
degree Fahrenheit	°F
degree (plane angle)	°
direct current	dc or DC*
farad	F
foot	ft
footcandle‡	fc
footlambert§	fL
foot per minute	ft/min
foot per second	ft/s
frequency modulation	FM
frequency-shift keying	FSK
gallon	gal
gauss¶	G
gigahertz	GHz
gram	g
henry	H
hertz	Hz
hour	h
inch	in
inductance-capacitance	LC

* As governed by context.

† Deprecated: the preferred (SI) unit is the meter (m). 1 Å = 0.1 nm

‡ Deprecated: the preferred (SI) unit is the lux (lx). 1 fc = 10.763 91 lx

§ Deprecated: the preferred (SI) unit is the candela per square meter (cd/m²). 1 fL = 3.426 259 cd/m²

¶ Deprecated: the preferred (SI) unit is the tesla (T). 1 G = 0.1 mT

Annex L (informative) Symbols and abbreviations (cont'd)

Unit or term	Symbol or abbreviation
infrared	IR
inside diameter	ID
joule	J
kelvin	K
kilogram	kg
kilohertz	kHz
kilometer per hour	km/h
lambert †	L
liter	l
lumen	lm
lux	lx
maximum	max, Max, or MAX*
megahertz	MHz
megawatt	MW
megohm	MΩ
meter	m
micrometer	μm
micron ‡	μ
mil	mil
mile per hour	mi/h
milliwatt	mW
minimum	min, Min, or MIN*
minute (plane angle)	'
minute (time)	min
nanosecond	ns
ohm	Ω
pound	lb
pulse-code modulation	PCM
pulse-repetition frequency	PRF
pulse-repetition rate	PRR
pulse-width modulation	PWM
roentgen	R
root-mean-square	rms or RMS*
second (plane angle)	"
second (time)	s
siemens	S
steradian	sr
typical	typ, Typ, or TYP*
volt	V
watt	W
yard	yd
year	y

* As governed by context.

† Deprecated: the preferred (SI) unit is the candela per square meter (cd/m²). 1 L = 3 183.099 cd/m²

‡ Deprecated: the preferred (SI) unit is the meter (m). 1 μ = 1 μm

Annex M (informative) Illustration of a manuscript layout

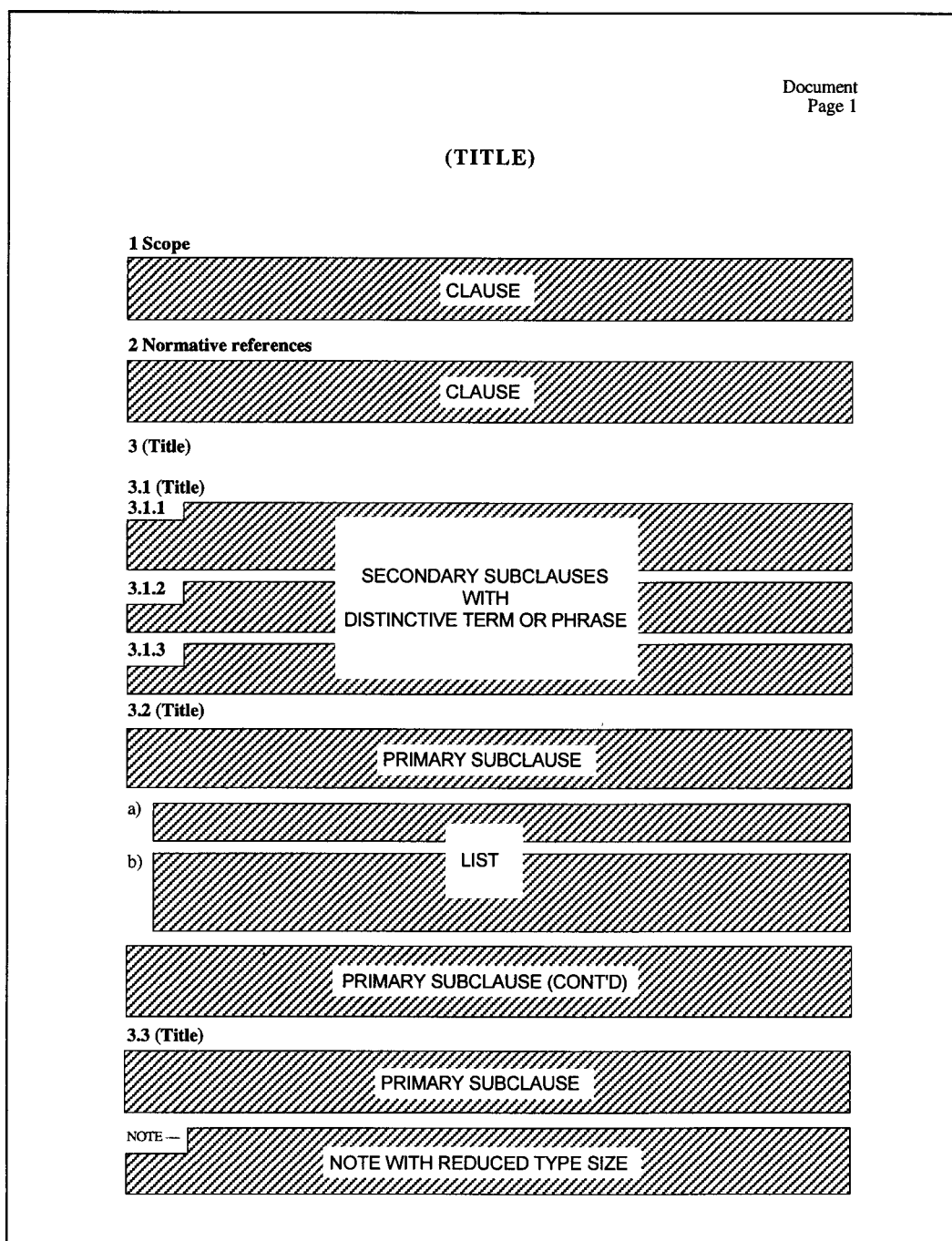

Annex M (informative) Illustration of a manuscript layout (cont'd)

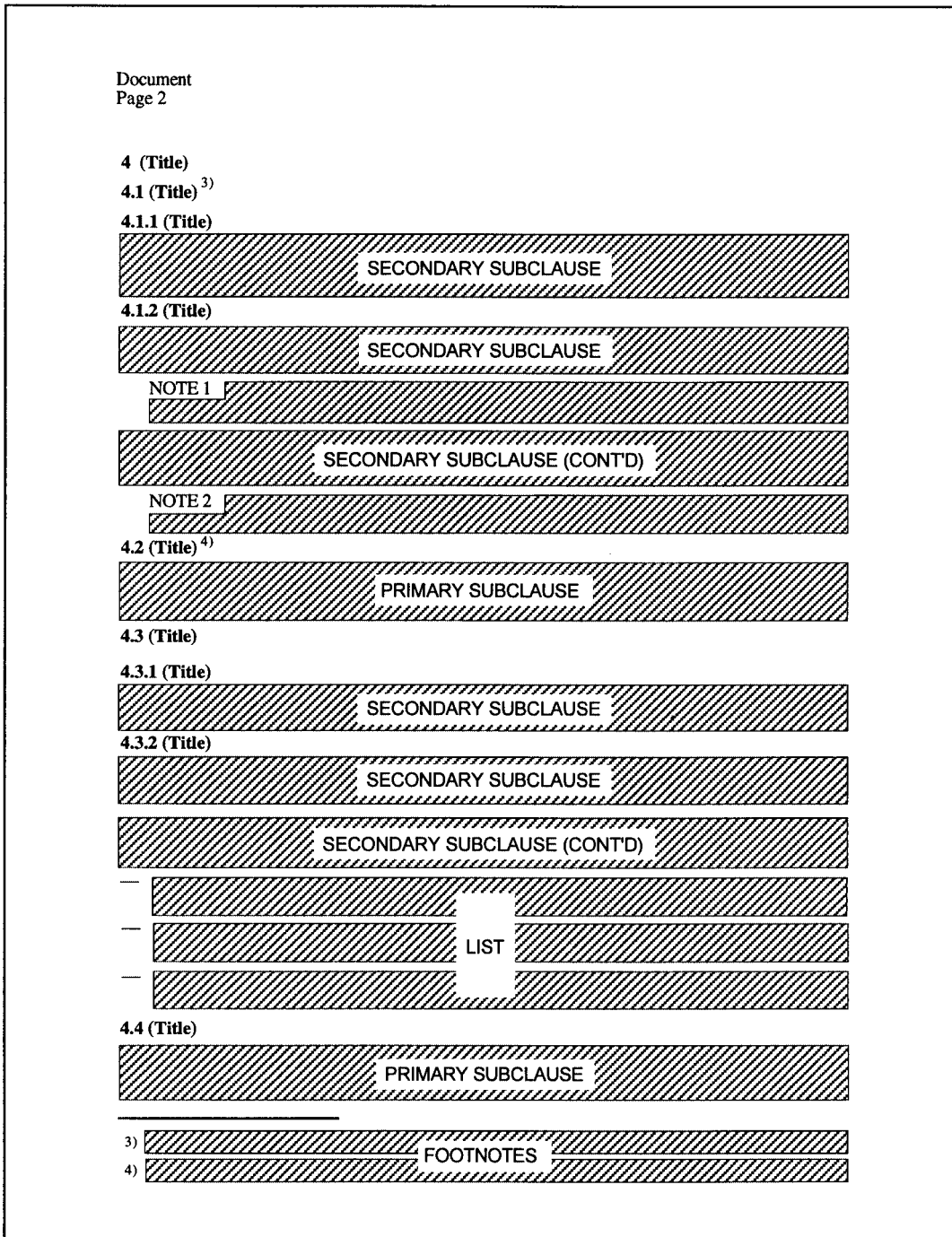

Index

A

a and *an* with acronyms, K.2
 Abbreviations, annex L
 see also Symbols and abbreviations
 and acronyms, 6.6.2.2
 and letter symbols (in tables), 6.6.5.8.4
 of names of organizations, 6.6.2.1
 Acronyms, 6.6.2.2
 a and *an* with, K.2
 Alternative terms (use to be avoided), 4.2
 Analogous wording for analogous provisions, 4.2
 Annexes, 5.2.7
 informative, 6.4.1
 normative, 6.3.9
 ANSI patent policies, 6.6.3.2
 ANSI standards, basic, annex C
 Appendixes, *see* Annexes
 Application notes (the element), 6.3.8
 Arrangement, general, 5.1.3
 Artwork, D.3

B

Bibliographic references, 6.4.2
 Bibliography, 5.2.8
billion, deprecation of, 6.6.7.6
 Brackets in terms and definitions, G.3.5.2

C

can, annex J
 Capitalization, 6.6.2.6
 Classification and designation (the element), 6.3.6
 Clauses, 5.2.3
 Comma to separate digits into groups of three,
 (deprecated), 6.6.7.3
 Common rules and elements, 6.6
 Compound adjectives, hyphenation of, 6.6.2.4.3
 Compound words and hyphenation, 6.6.2.4
 compound adjectives, 6.6.2.4.3
 general, 6.6.2.4.1
 prefixes, 6.6.2.4.2
 usage of hyphens and dashes, 6.6.2.4.5
 word division, 6.6.2.4.4
 Consistency of basic standards, 4.3
 Contents, *see* Table of Contents
 Copyrighted material, 6.6.3.3
 Cover (page), 6.1.1

D

Dashes, *see* Hyphens and dashes
 Data, format and presentation of in tables, 6.6.5.8
 Dated references, 6.6.6.5.2

Decimal, preceded by zero for values less
 than one, 6.6.7.2
 Decimal sign, 6.6.7.1
 Definitions, 3
 see also Terms and definitions (the element)
 drafting of, annex G
 Diagrams, 6.6.4.7
 Dictionaries to be used, 6.6.2.1
 Differences, EP-7-C vs EP-7-B, annex B
 Differences, EP-7-C vs IEC Directives,
 Part 3, 1997, annex A
 Dimensions, 6.6.5.8.3
 Dimensions and tolerances, 6.6.10
 Divisions and subdivisions
 descriptions of, 5.2
 examples of numbering of, annex F
 general, 5.1.1
 names of, 5.1.1
 numbering of, 5.2
 Document submission for publication, D.2
 Document titles, annex H
 Drafting, 6
 Drafting of terms and definitions, annex G
 Drafts, *see* Presentation of typescripts

E

EIA patent policies, 6.6.3.2
 EIA Publications Office, annex E
 EIA standards, basic, annex C
 Equations, *see* Mathematical formulas
 Examples, 6.5.1

F

Figures, 6.6.4
 footnotes to, 6.6.4.9
 form of, 6.6.4.2
 informal, 6.6.4.10
 layout, 7.2.2
 notes to, 6.6.4.8
 numbering of, 6.6.4.3
 titles, layout of, 6.6.4.4
 usage of, 6.6.4.1
 Final approval by committee chair, E.3
 Final manuscript, preparation of, annex D
 Fonts, 7.3
 Footnotes
 to figures, 6.6.4.9
 to tables, 6.6.5.7
 to the text, 6.5.2
 type size of, 7.3.4
 Foreword (the element), 6.1.4

Formulas, mathematical, 6.6.9
Frequently misused words and phrases, 6.6.2.8

G

General arrangement, 5.1.3
General normative elements, 6.2
Grammar, 6.6.2

H

Homogeneity, 4.2
Hyphen with quantity used as adjective, 6.6.8.3
Hyphenation, *see* Compound words and hyphenation
Hyphens and dashes, usage (length) of, 6.6.2.4.5

I

Identical wording for identical provisions, 4.2
IEEE standards, basic, annex C
Implementation, 4.4
Indentation in tables, 6.6.5.8.2
Indexes, 5.2.9, 6.4.3
Informal figures, 6.6.4.10
Informal tables, 6.6.5.9
Informative annexes, 6.4.1
Informative element, 6.5
 (definition), 3.3
Instruction (definition), 3.6.2
International standard (definition), 3.1.1
International standards, facilitate adoption as, 4.4
International System (SI) units, 6.6.8.3
Introduction (the element), 6.1.5
Italic type used with symbols, 6.6.4.5

J

JEDEC standards, basic, annex C

L

Labeling, 6.3.7
Landscape format, 7.2.2
Layout example, annex M
Legal policies, 4.7, 6.3.3
Letter symbols, 6.6.4.5, 6.6.8.2
Lettering, style, 6.6.4.5
Lists, 5.2.6

M

Manuscripts, annex D
Margins, 7.1
Marking, labeling, and packaging
 (the element), 6.3.7
Mathematical expressions, D.4
Mathematical formulas, 6.6.9
 multiplication signs, 6.6.7.4
 numbering of equations, 6.6.9.3
 presentation (space-saving techniques), 6.6.9.2
 signs and symbols, 6.6.8.1

Mathematical formulas, (cont'd)
 symbols, preferred sources for, 6.6.8.2
 types of equations, 6.6.9.1
may, annex J
Misused words and phrases, 6.6.2.8
Multiple meanings of terms, G.3.4
Multiplication signs, 6.6.7.4

N

Nomenclature for parts of tables, 6.6.5.8.1
Normative annexes, 6.3.9
Normative elements
 (definition), 3.2
 general, 6.2
 technical, 6.3
Normative references, 2
Normative references (the element), 6.2.2
Notes
 to figures, 6.6.4.8
 integrated into the text, 5.1.3, 6.5.1
 to tables, 6.6.5.6
 type size of, 7.3.4
Notice (on back of front cover), 6.1.2
Numbering
 of clauses, 5.2.2, 5.2.3, 5.2.7
 of figures, 6.6.4.3
 of mathematical formulas, 6.6.9.3
 of pages, 6.6.11
 of sections, 5.2.2
 of subclauses, 5.2.4, 5.2.7
 of tables, 6.6.5.2
Numbers, expression of, 6.6.7.5
Numbers, when to spell out, 6.6.7.5
Numerical values, representation of, 6.6.7

O

Objective, 4.1
Optional element (definition), 3.5
Organizations, spelling and abbreviation of
 names of, 6.6.2.1

P

Packaging, 6.3.7
Page dimensions, 7.1
Page heading, 6.6.12
Page numbers, 6.6.11
Paragraphs, 5.2.5
Parentheses in terms, G.3.5.1
Part (of a standard), 5.2.1
Patent policies, EIA and ANSI, 6.6.3.2
Percentages, tolerances on, 6.6.10
Planning, 4.5
Policies, legal, 4.7
Policies, procedural, 4.6
Portrait format, 7.2.1

Prefixes, hyphenation of, 6.6.2.4.2
Preliminary elements, 6.1
 (definition), 3.3.1
Presentation of typescripts, 7
Procedural policies, 4.6
Provision (definition), 3.6
Publication, document submission for, D.2

Q

Quantities, units, symbols, and signs, 6.6.8

R

Recommendation (definition), 3.6.3
Reference number (on cover), 6.1.1
References, 6.6.6.
 to articles in periodicals, 6.4.2.2
 bibliographic, 6.4.2
 to books, 6.4.2.3
 to other documents, 6.6.6.5
 to the standard in its own text, 6.6.6.2
 to tables and figures, 6.6.6.4
 to text in another standard, 6.6.6.3.2
 to text in same standard, 6.6.6.3.1
Related EIA documents, 6.4.4
Required element (definition), 3.4
Requirement (definition), 3.6.4
Requirements (the element), 6.3.3
Rounding, 6.6.5.8.3
Ruled lines in tables, 6.6.5.8.5
Runover lines in tables, 6.6.5.8.1

S

Sampling (the element), 6.3.4
Scope, 1
Scope (the element), 6.2.1
Section (of a standard), 5.2.2
Separation of digits into groups of three, 6.6.7.3
shall, annex J
should, annex J
SI units, 6.6.8.3
Signs, 6.6.8
Similarities with non-EIA standards,
 statement outlining, 6.1.2
Special needs, 6.6.13
Spelling, 6.6.2.1, K.1
Square brackets in terms and definitions, G.3.5.2
Standard (definition), 3.1
Standards, consistency of basic, 4.3
Standards, list of basic, annex C
State of the art (definition), 3.7
Statement (definition), 3.6.1
Statement outlining similarities with non-EIA
 standards, 6.1.2
Structure, 5
Style, 6.6.2.3

Subclauses, 5.2.4
Subdivision, 5.1
 see also Divisions and subdivisions
 within an individual standard, 5.1.3
 within a series of parts, 5.1.2
Subscripts, 6.6.9.2, 7.3.3
Superscripts, 7.3.3
Supplementary elements, 6.4
 (definition), 3.3.2
Symbols, 6.6.4.5, 6.6.8
Symbols and abbreviations
 (the element), 6.3.2
 list of, annex L
Synonyms, G.3.3
Synonyms (use to be avoided), 4.2

T

Table of contents (the element), 6.1.3
Tables, 6.6.5
 abbreviations and letter symbols, 6.6.5.8.4
 continuation of, 6.6.5.5
 footnotes to, 6.6.5.7
 format and presentation of data, 6.6.5.8
 headings in, 6.6.5.4
 informal, 6.6.5.9
 layout, 7.2.2
 nomenclature for parts of, 6.6.5.8.1
 notes to, 6.6.5.6
 numbering of, 6.6.5.2
 ruled lines in, 6.6.5.8.5
 runover lines in, 6.6.5.8.1
 summary (with example table), 6.6.5.8.6
 titles, layout of, 6.6.5.3
 type size in, 7.3.4
 usage of, 6.6.5.1
Technical drawings, 6.6.4.6
Technical normative elements, 6.3
Terminology standards
 arrangement of terms in, G.2
 types of, G.1.1
Terms and definitions, 3
 drafting, annex G
 (the element), 6.3.1
 layout, G.3.2
 multiple meanings of terms, G.3.4
 parentheses and brackets, G.3.5
 synonyms, G.3.3
Test methods (the element), 6.3.5
that and *which*, 6.6.2.7
Text layout, 7.2.1
Thousands, separation of, 6.6.7.3
Title (the element), 6.1.1

T

Titles
of clauses, 5.2.3
of documents, annex H
of figures, 6.6.4.4
of sections, 5.2.2
of subclauses, 5.2.4
of tables, 6.6.5.3
typography of, 7.3.1
Tolerances, 6.6.10
Trade names, use of, 6.6.3.1
trillion, deprecation of, 6.6.7.6
Type size, 7.3
Typescripts, *see* Manuscripts
Typography, 7.3

U

Undated references, 6.6.6.5.3
Units, 6.6.8

V

Values of measure, 6.6.7.2
Verbal forms, annex J
Verbal forms for the expression of
provisions, 6.6.1

W

which and *that*, 6.6.2.7
Widows and orphans, 6.6.2.5
will, annex J
Word division, hyphenation with, 6.6.2.4.4
Wording, proper, K.2
Wraparounds in tables, 6.6.5.8.1

Z

Zero preceding decimal for values less than one,
6.6.7.2

